**Plastics — Determination of thermal
conductivity and thermal diffusivity —**

Part 6:

**Comparative method for low thermal
conductivities using a temperature-
modulation technique**

*Plastiques — Détermination de la conductivité thermique et de la
diffusivité thermique —*

*Partie 6: Méthode comparative pour faibles conductivités thermiques
utilisant une technique de modulation de la température*





COPYRIGHT PROTECTED DOCUMENT

© ISO 2014

All rights reserved. Unless otherwise specified, no part of this publication may be reproduced or utilized otherwise in any form or by any means, electronic or mechanical, including photocopying, or posting on the internet or an intranet, without prior written permission. Permission can be requested from either ISO at the address below or ISO's member body in the country of the requester.

ISO copyright office
Case postale 56 • CH-1211 Geneva 20
Tel. + 41 22 749 01 11
Fax + 41 22 749 09 47
E-mail copyright@iso.org
Web www.iso.org

Published in Switzerland

Contents

	Page
Foreword	iv
Introduction	v
1 Scope	1
2 Normative references	1
3 Terms and definitions	2
4 Principle	3
5 Apparatus	4
6 Test specimens	5
6.1 Measuring temperature.....	5
6.2 Geometry of the probe material.....	5
6.3 Specimen area size.....	6
6.4 Specimen thickness.....	6
7 Procedure	6
8 Expression of results	6
8.1 Graphical presentation.....	6
8.2 Verification.....	7
9 Test report	7
Annex A (informative) Results of thermal conductivity of cellular plastics	9
Annex B (informative) Infinite thickness	11
Bibliography	12

Foreword

ISO (the International Organization for Standardization) is a worldwide federation of national standards bodies (ISO member bodies). The work of preparing International Standards is normally carried out through ISO technical committees. Each member body interested in a subject for which a technical committee has been established has the right to be represented on that committee. International organizations, governmental and non-governmental, in liaison with ISO, also take part in the work. ISO collaborates closely with the International Electrotechnical Commission (IEC) on all matters of electrotechnical standardization.

The procedures used to develop this document and those intended for its further maintenance are described in the ISO/IEC Directives, Part 1. In particular the different approval criteria needed for the different types of ISO documents should be noted. This document was drafted in accordance with the editorial rules of the ISO/IEC Directives, Part 2 (see www.iso.org/directives).

Attention is drawn to the possibility that some of the elements of this document may be the subject of patent rights. ISO shall not be held responsible for identifying any or all such patent rights. Details of any patent rights identified during the development of the document will be in the Introduction and/or on the ISO list of patent declarations received (see www.iso.org/patents).

Any trade name used in this document is information given for the convenience of users and does not constitute an endorsement.

For an explanation on the meaning of ISO specific terms and expressions related to conformity assessment, as well as information about ISO's adherence to the WTO principles in the Technical Barriers to Trade (TBT) see the following URL: Foreword - Supplementary information

The committee responsible for this document is ISO/TC 61, *Plastics*, Subcommittee SC 5, *Physical-chemical properties*.

ISO 22007 consists of the following parts, under the general title *Plastics — Determination of thermal conductivity and thermal diffusivity*:

- *Part 1: General principles*
- *Part 2: Transient plane heat source (hot disc) method*
- *Part 3: Temperature wave analysis method*
- *Part 4: Laser flash method*
- *Part 5: Results of interlaboratory testing of poly(methyl methacrylate) samples* [Technical Report]
- *Part 6: Comparative method for low thermal conductivities using a temperature-modulation technique*

Introduction

Thermal insulating properties have become more important in view of power-saving technology. The method which is applicable to measure the lower thermal conductivity in smaller scale with a small amount of a specimen, such as a tray for food, a thermal printing film, a gelled sheet for the electric parts inside laptop PC, an adhesive paste, etc., is required for the micro-scale thermal design of plastics. A double-sensor system of high-sensitivity thermopile located in the different distances in the modulated temperature field, which is controlled by the Peltier thermo-module, is proposed for the determination of thermal conductivity of plastics. A decay parameter is utilized to determine the thermal conductivity of the sample. This method is applied to the measurement of low thermal conductivity in the range below 1,0 W/mK.

In contrast to a pulse or a transient method, high sensitivity and high-temperature resolution are characteristic of temperature modulated technique, in which employment of a lock-in amplifier reduces any influence of noise and interference.

The thermal conductivity of materials that are poor conductors of heat is usually determined by measuring the larger temperature gradients in the sample produced by a steady flow of heat in one-dimensional geometry. In order to reduce the errors of radiation and convection, it often requires large, precisely shaped samples and extreme care to be used successfully.

This part of ISO 22007 specifies a modulated temperature method to determine the thermal conductivity with a small temperature variation, minimizing the influence of radiation and convection.

Plastics — Determination of thermal conductivity and thermal diffusivity —

Part 6: Comparative method for low thermal conductivities using a temperature-modulation technique

1 Scope

This part of ISO 22007 specifies a modulated temperature method realizing the measurement of thermal conductivity. An input of temperature deviation is less than 1 K, and a double lock-in method is applied to amplify the small temperature modulation.

ISO 22007-3 specifies one of the modulated temperature methods where the phase shift is measured in the thermally thick condition, $kd \gg 1$ [$k = (\omega/2\alpha)^{1/2}$, ω : angular frequency of temperature wave, α : thermal diffusivity, and d : thickness of the specimen]. In this condition, the backing material does not affect on the phase shift results on the sensor, on which temperature wave decays exponentially.

On the other hand, if $kd \ll 1$, the decay of temperature modulation is influenced by the backing materials. Based on this principle, this part of ISO 22007 specifies the method to determine the thermal conductivity of the sample (as a backing material), comparing the decay of temperature wave detected on both surfaces of the probe material.

Thermal conductivity is determined from the correlation between the thermal impedance and the decay ratio of amplitude using two reference materials measured at the same frequency and temperature.

The covering thermal conductivity range is adjusted with the reference materials and the probe materials. Basically, thermal conductivity is determined in the range from 0,026 W/mK to 0,6 W/mK.

In the case applying the method to inhomogeneous materials, cares must be taken to choose the appropriate measurement conditions in accordance with the thermal penetration depth.

2 Normative references

The following documents, in whole or in part, are normatively referenced in this document and are indispensable for its application. For dated references, only the edition cited applies. For undated references, the latest edition of the referenced document (including any amendments) applies.

ISO 472, *Plastics — Vocabulary*

ISO 22007-1, *Plastics — Determination of thermal conductivity and thermal diffusivity — Part 1: General principles*

ISO 22007-3, *Plastics — Determination of thermal conductivity and thermal diffusivity — Part 3: Temperature wave analysis method*

ISO/TR 22007-5, *Plastics — Determination of thermal conductivity and thermal diffusivity — Part 5: Results of interlaboratory testing of poly(methyl methacrylate) samples*

ISO 80000-5, *Quantities and units — Part 5: Thermodynamics*

3 Terms and definitions

For the purposes of this document, the terms and definitions given in ISO 472, ISO 22007-1, ISO 22007-3, ISO 80000-5, and the following apply.

3.1 amplitude of temperature modulation

Amp
amplitude of the temperature oscillation produced by a modulated-power heat source

Note 1 to entry: It is expressed in Kelvin.

3.2 gain

ζ
ratio of *Amp* at $x = d$ to $x = 0$; amplitude ratio of the front ($x = 0$) and rear ($x = d$) surfaces of the probe material

$$\zeta = \frac{T_d}{T_0} = \frac{Amp_{x=d}}{Amp_{x=0}}$$

where

T_0 and T_d are the amplitude of modulated temperature measured on the sensor 1 (at $x = 0$) and the sensor 2 ($x = d$), respectively.

3.3 thermal penetration depth

D_p
periodic oscillations in temperature can only be observed for the depths less than D_p , defined as

$$D_p = 2\pi \sqrt{\frac{2\alpha}{\omega}}$$

where

α is thermal diffusivity;

ω is angular frequency;

D_p is the depth at which the amplitude of the temperature oscillation has been attenuated to 0,19 % as derived from $\exp\left(-\sqrt{\frac{\omega}{2\alpha}}D_p\right) = \exp(-2\pi) \cong 0,0019$.

Note 1 to entry: The thermal penetration depth is expressed in metres.

3.4 thermal diffusion length

$1/k$
where

$$k \text{ is defined as } \sqrt{\frac{\omega}{2\alpha}}$$

Note 1 to entry: The thermal diffusion length is expressed in metres. k is expressed in reciprocal metres.

4 Principle

As depicted in [Figure 1](#), the probe material in a flat sheet shape is set between the heat source and the sample, assuming the one-dimensional heat flow.

The heat source generates a temperature modulation at a constant amplitude, keeping the average temperature constant that is realized by using a thermo-electric type (Peltier type) temperature control. Due to the large heat capacity of the heat sink, the temperature modulation in the heat source is not affected by the sample, and the input temperature ($x = 0$) on the probe is kept constant.

The sample is attached to the other side of the probe material. In the thermally thin condition, $kd \ll 1$, the decaying temperature modulation at $x = d$ is influenced by the sample.

The modulated temperatures at $x = 0$ and $x = d$ are precisely measured by the attached temperature sensor, respectively, using a lock-in amplification.

The characteristic of the principle is listed as below.

- A small temperature change of the modulated temperature, for instance, less than ± 1 K, is given at a surrounding temperature. The average temperature is kept at a surrounding temperature, using a thermo-electric type (Peltier-type) temperature control.
- The temperature at a bottom of the heat sink (an opposite side from $x = 0$ in [Figure 1](#)), a deep location in the sample (an opposite side from $x = d$ in [Figure 1](#)), and the cold-junction of the thermopile sensor, are considered as the surrounding temperature.
- A one-dimensional heat flow is attained, measuring a small area located in the centre of the plane heat flow.
- The frequency for the measurement is chosen considering the thermal diffusion length of a probe material.
- The lock-in amplification, that is characteristic of the modulation technique, enables to measure the small temperature variation that minimizes the influence of the radiation and convection.

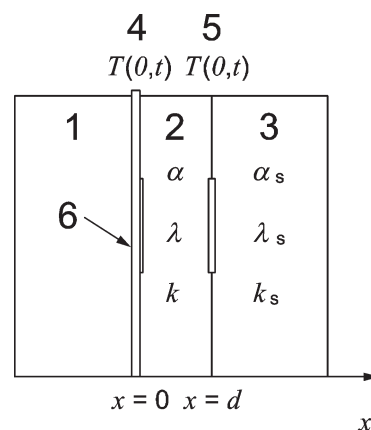

Key

- 1 heat sink
- 2 probe material
- 3 sample
- 4 sensor 1
- 5 sensor 2
- 6 heater (Peltier module)
- x direction of sample thickness

Figure 1 — Geometry of two sensors and one Peltier heat source

5 Apparatus

The apparatus shall be designed to obtain the gain as defined in 3.2 and shall consist of the following main components as shown in Figure 2.

5.1 Heat sink, with heat capacity that is so large as to estimate the bottom temperature (on the opposite side from $x = 0$) at room temperature.

5.2 Thermoelectric module and two sensor elements, with the following characteristics.

5.2.1 Thermoelectric-module that generates a temperature oscillation by passing alternating current through a Peltier-type heat source attached to the front surface of the probe materials; it is assumed to be located at $x = 0$ (see Figure 2).

5.2.2 Sensor element is a thermopile, of which a cold-junction is attached to the surrounding temperature area and a hot-junction located in the mid area detects the temperature variation by the differential amplification.

5.2.3 Sensor elements (sensor 1 and sensor 2) are located at $x = 0$ and $x = d$, respectively, in order to measure the amplitude of the temperature oscillation on the front and rear surfaces of the probe material in Figures 2 and 3.

5.3 Probe materials, with thermal properties α : thermal diffusivity, λ : thermal conductivity, k : $k = (\omega/2\alpha)^{1/2}$, ω : angular frequency of temperature wave and thickness, d , is located between the heat source and the sample (α_s , λ_s , and k_s).

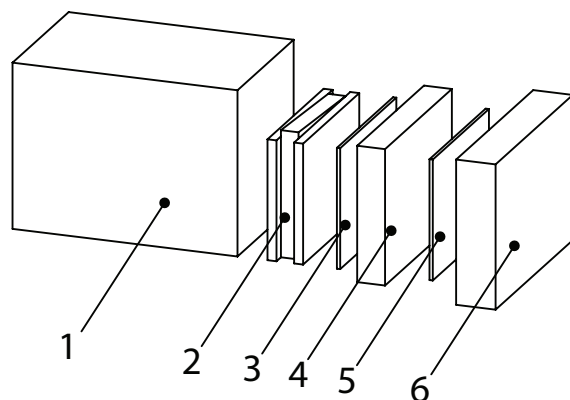

Key

- 1 heat sink
- 2 Peltier module
- 3 sensor 1 → lock-in amplifier 1
- 4 probe materials
- 5 sensor 2 → lock-in amplifier 2
- 6 sample

Figure 2 — Schematic diagram of the measuring geometry

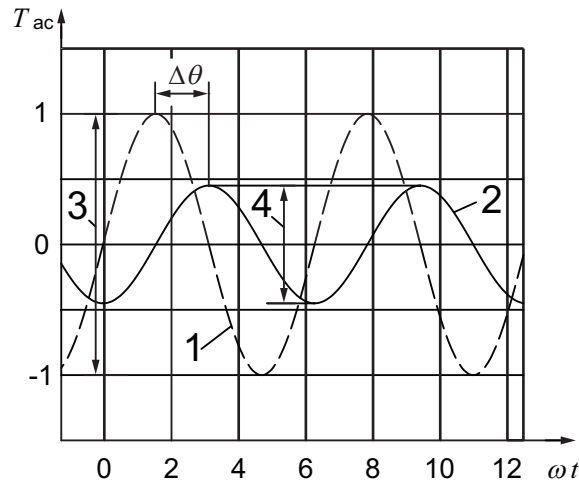

Key

1 sensor 1

2 sensor 2

3 amplitude 1

4 amplitude 2

T_{ac} modulated temperature on a sensor in K

t time

ω angular frequency of temperature wave

Figure 3 — Schematic view of the temperature modulation observed on sensor 1 and sensor 2

NOTE 1 An example of sensor element is a thermopile with thermoelectric temperature sensors.

NOTE 2 Much smaller sensor area size is required than the area size of Peltier module in order to realize the one-dimensional thermal diffusion. Typically, a Peltier module of 30 mm × 30 mm size is used as a temperature modulating power source and for detecting the temperature curve a thermopile in the area size of 5 mm × 2 mm.

5.4 Heating circuit, the power applied to the Peltier module shall be adjusted such as to obtain a high signal to noise ratio on sensors.

NOTE Typically the amplitude of modulated temperature on the Peltier thermo-module is smaller than ± 1 K.

5.5 Measuring circuit, a thermoelectric voltage from the temperature sensor is measured with a two-phase lock-in amplifier.

6 Test specimens

6.1 Measuring temperature

Another temperature sensor is fixed onto the cold junction. This is the surrounding temperature.

6.2 Geometry of the probe material

The probe material should have the thickness corresponding to the thermal diffusion length $\left(d_{\text{probe}} = 1/k, k = \sqrt{\frac{\omega}{2\alpha_{\text{probe}}}} \right)$. For a probe material with a known thickness, the frequency of temperature

wave is chosen based on the thermal diffusivity of the probe material. The area size of the probe material is recommended as the similar one of the Peltier module.

NOTE The cast grade sheet, 0,5 mm in thickness, of poly(methyl methacrylate) (PMMA) can be used as a probe material. (See ISO/TR 22007-5 in accordance with the thermal properties of the cast grade PMMA.) The probe materials having the similar thermal properties to the sample's is preferable.

6.3 Specimen area size

The area of the specimen shall be larger than the sensor area size. Preferably, one side of a square of the specimen is at least 10 times larger than that of the sensor area.

6.4 Specimen thickness

The sample thickness is preferable larger than D_p in the sample. If the thermal properties of the sample and the probe material are similar, the five to six times of thermal diffusion length of the probe material is an estimate. The temperature in the sample decays to the surrounding temperature on the opposite side from $x = d$.

The practical guidance for choosing the optimal set of thickness and frequency is introduced in [Annex B](#) where the decay condition for 0,01 is simulated.

7 Procedure

7.1 Measure the thickness of the specimen.

7.2 Assemble the test pieces onto the thermopile sensor. If required, a load of the assembled device can be used.

7.3 Place the assembled device containing the specimen in the furnace. Connect the Peltier module to the power source and the sensor to the phase detector.

7.4 Raise or lower the temperature of the furnace to the test temperature, in the range from 5 °C to 50 °C, with a temperature scan rate not more than 10 K/min.

7.5 Check the specimen temperature.

7.6 Close the measuring circuit and generate an oscillating current on the Peltier module. The power should be adjusted to obtain a high signal-to-noise ratio of the amplitude of temperature wave on sensors.

7.7 Measure the phase difference and the amplitude of the temperature wave at $x = 0$ and $x = d$ at a fixed frequency with a phase detector such as a lock-in amplifier, with a reference signal from the function synthesizer. Calculate the gain of the sample.

8 Expression of results

8.1 Graphical presentation

The gain, ζ , the amplitude ratio of the front and rear surfaces of the probe material, is obtained from the measurement. The gains of two materials (ref. 1 and ref. 2) are determined in the same experimental conditions, at a certain frequency and a surrounding temperature. [Table 1](#) shows the correlation between the inverse of the measured gain and thermal conductivity of materials (water and air) and the probe material (PMMA; 0,5 mm thickness) at frequency 0,05 Hz at a surrounding temperature.

Table 1 — Correlation between the measured gain and thermal conductivity of materials

Samples	ζ (measured)	$1/\zeta$	λ (W/mK)
air (ref. 1)	0,83	1,2	0,026
water (ref. 2)	0,21	4,8	0,61
PMMA (probe)	0,46	2,2	0,18
silicone rubber	0,48	2,1	0,16
PS foam	0,78	1,3	N/A

The plot of thermal conductivity, λ , versus a reciprocal of the gain, $1/\zeta$, gives a linear correlation as depicted in [Figure 4](#), giving thermal conductivity, λ , from the measured results of ζ .

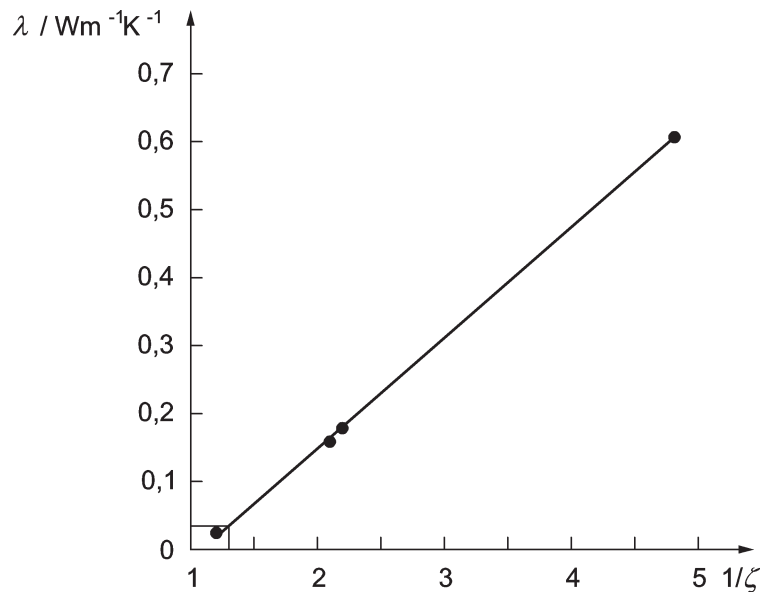
**Figure 4 — Plot of $1/\zeta$ vs. λ with the reference and probe materials listed in [Table 1](#)**

NOTE A recommended standard reference material is NIST 1453 (cellular PS). A PMMA sheet was measured in ISO 22007-5. Such a material can be useful in benchmarking the method.

8.2 Verification

Verification of the method and the apparatus can be achieved by undertaking measurements on standard reference materials, preferably covering the property and temperature range of the materials to be tested. The recommended magnitude of the allowed deviation detected during verification is less than $\pm 3\%$ from the reference values. The measurement conditions should be re-examined and/or the apparatuses re-calibrated until the verification is successful. For the homogeneous samples, the repeatability less than $\pm 3\%$ and the deviation $\pm 5\%$ at a fixed temperature are recommended.

9 Test report

The test report shall contain at least the following information:

- name and address of the testing laboratory;
- the date of the test;
- a reference to this part of ISO 22007 (i.e. ISO 22007-6);

ISO 22007-6:2014(E)

- d) identification of the probe material and the specimen tested (manufacturer, product, type, batch number, etc.), and details of its thermal history;
- e) shape, thickness, other dimensions, and number of probe materials and specimens;
- f) manufacturer of instrument, model and type;
- g) type, shape, dimensions, and electric resistances of sensor and Peltier module;
- h) measurement conditions, such as temperature, modulated power to Peltier module, furnace atmosphere, frequency of temperature wave;
- i) testing results, such as decay ratios and phase shifts at respective frequencies and temperatures;
- j) plot the inverse of gain of the standard reference materials in the plot of thermal conductivity. (see [Figure 4](#));
- k) any other relevant items;
- l) information on the reference material (nature, manufacturer, thermal properties).

.....

Annex A (informative)

Results of thermal conductivity of cellular plastics

[Table A.1](#) shows the results of thermal conductivity of cellular materials; measured at 0,05 Hz, with a probe material poly(methyl methacrylate) of 0,5 mm thickness, at 27 °C. Air and water are chosen for reference materials.

Table A.1 — Results of thermal conductivity of cellular materials

	Plane view $\lambda/Wm^{-1}K^{-1}$	Side view $\lambda/Wm^{-1}K^{-1}$	Literature data ^d $\lambda/Wm^{-1}K^{-1}$
EPS ^a (NIST ^b 1453)	0,037 0 ± 0,000 153	0,035 0 ± 0,000 173	0,033 6 - 0,034 0
LI900(NASA ^c)	0,045 0 ± 0,000 185	0,043 0 ± 0,000 135	0,045 - 0,050
^a Expanded polystyrene. ^b National Institute of Standards and Technology. ^c National Aeronautics and Space Administration. ^d Certificate data of standard reference material NIST1453.			

[Table A.2](#) shows the results of thermal conductivity of EPS; measured at 0,05 Hz, with a probe material poly(methyl methacrylate) of 0,5 mm thickness, at 27 °C. Air and water are chosen for reference materials.

Table A.2 — Results of thermal conductivity

	Plane view 1 (front) $\lambda/Wm^{-1}K^{-1}$	Plane view 2 (rear) $\lambda/Wm^{-1}K^{-1}$	Core layer 1 ^c $\lambda/Wm^{-1}K^{-1}$	Core layer 2 ^c $\lambda/Wm^{-1}K^{-1}$
EPS ^a (NIST ^b 1453)	0,037 0 ± 0,000 153	0,038 1 ± 0,000 115	0,035 0 ± 0,000 173	0,035 1 ± 0,000 156
^a Expanded polystyrene. ^b National Institute of Standards and Technology. ^c Measuring direction and geometry are shown in Figure A.1 .				

[Figure A.1](#) shows a schematic view of the measuring direction of the specimens in [Table A.1](#) and [Table A.2](#).

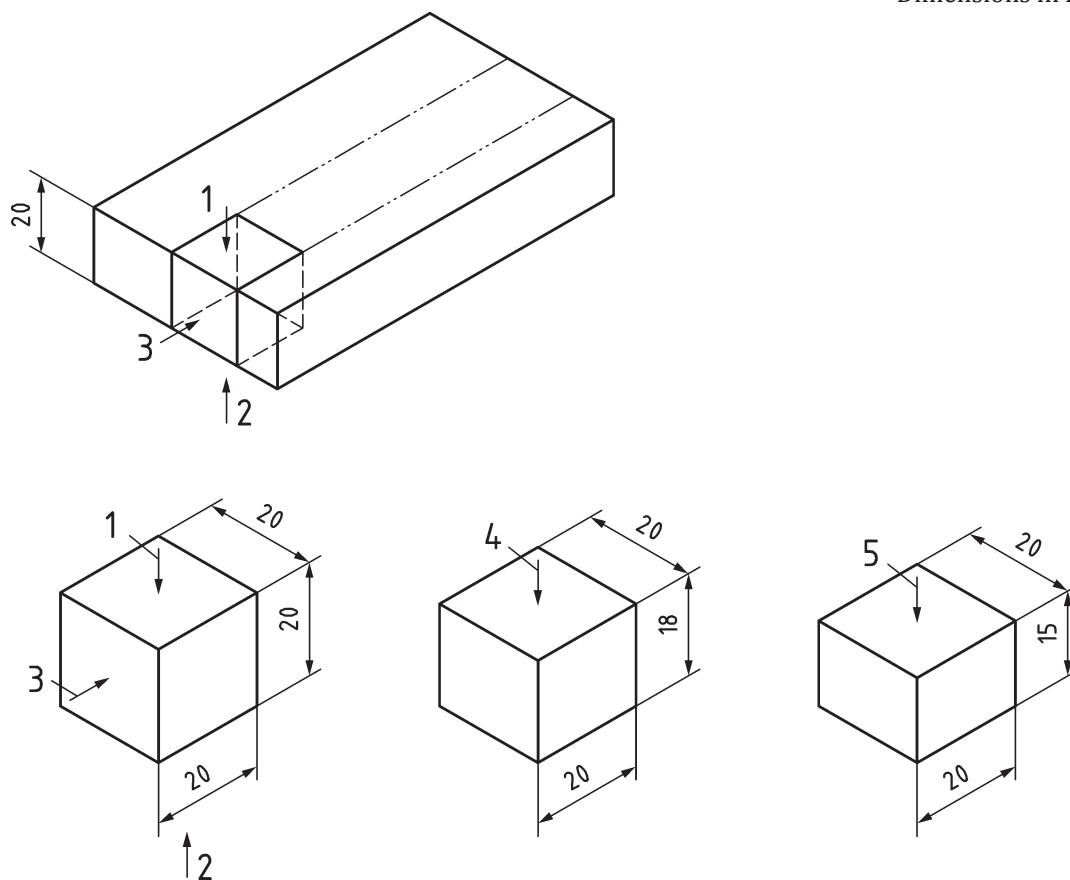

Key

- 1 plane view 1 (front)
- 2 plane view 2 (rear)
- 3 side view
- 4 core layer 1
- 5 core layer 2

Figure A.1 — Schematic view of the measuring direction of the specimens in [Table A.1](#) and [Table A.2](#)

Annex B (informative)

Infinite thickness

The apparent infinite thickness, where the thermal wave enough attenuates to 0,01 and thermal impedance becomes constant, is simulated as a function of frequency in [Figure B.1](#). The correlation between thickness and frequency gives a preferable condition to be realized in the experiments.

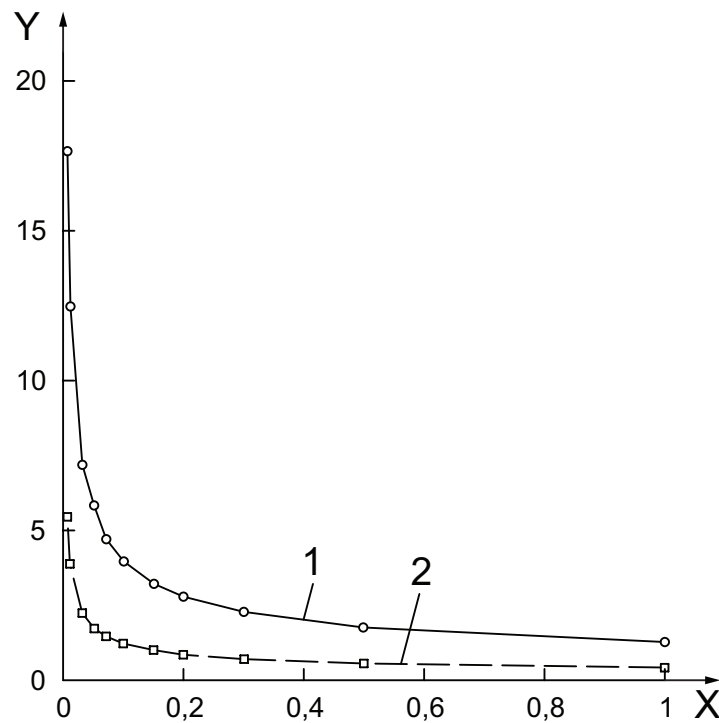

Key

- X frequency, Hz
- Y apparent infinite thickness, mm
- 1 EPS
- 2 PS

Figure B.1 — The apparent infinite thickness, in which the 99 % attenuation is realized in the thickness direction of the specimen, is shown as a function of frequency

Table B.1 — Estimate of the apparent infinite thickness of EPS and PS calculated at 0,05 Hz extracted from [Figure B.1](#)

		Frequency					
		0,01/Hz	0,03/Hz	0,05/Hz	0,07/Hz	0,1/Hz	0,5/Hz
Infinite thickness	EPS/mm	12,5	7,2	5,9	4,7	4,0	1,8
	PS/mm	3,9	2,2	1,7	1,5	1,2	0,55

Bibliography

- [1] ISO 291, *Plastics — Standard atmospheres for conditioning and testing*
- [2] ISO/IEC Guide 98-3, *Uncertainty of measurement — Part 3: Guide to the expression of uncertainty in measurement (GUM:1995)*

.....

ICS 83.080.01

Price based on 12 pages