

Thermal Diffusivity of Single-Walled Carbon Nanotube Forest Measured by Laser Flash Method

Megumi Akoshima*, Kenji Hata¹, Don N. Futaba¹, Kohei Mizuno, Tetsuya Baba, and Motoo Yumura¹

National Metrology Institute of Japan (NMIJ), National Institute of Advanced Industrial Science and Technology (AIST), Tsukuba Central 3, 1-1-1 Umezono, Tsukuba, Ibaraki 305-8563, Japan

¹Nanotube Research Center, National Institute of Advanced Industrial Science and Technology (AIST), Tsukuba Central 5, 1-1-1 Higashi, Tsukuba, Ibaraki 305-8565, Japan

Received October 27, 2008; revised March 4, 2009; accepted March 4, 2009; published online May 20, 2009

The science and technology of carbon nanotubes are very interesting topics in the field of nanotechnology. It is considered that such nanotubes have excellent properties of electrical conduction, tensile strength, and thermal conduction. However, these properties are not well understood yet. Techniques for handling a nanotube and measuring these properties have not yet been established. Recently, a technique for synthesizing supergrowth carbon nanotubes, which form a highly pure single-walled carbon nanotube (SWNT) forest, has been developed. These supergrowth carbon nanotubes grow to as long as a millimeter scale. As-grown supergrowth carbon nanotubes include about 5×10^{11} SWNTs per square centimeter. The solid of supergrowth carbon nanotubes is prepared by reducing the distance between SWNTs. We have investigated the thermal conduction of such carbon nanotubes and were successful in measuring the thermal diffusivity of self-standing samples of as-grown supergrowth carbon nanotubes and their solid using the laser flash method. It was found that the carbon nanotube samples show a comparable thermal diffusivity to isotropic graphite. We have also measured the temperature dependence of the thermal diffusivity of the supergrowth carbon nanotube samples. © 2009 The Japan Society of Applied Physics

DOI: 10.1143/JJAP.48.05EC07

1. Introduction

Carbon nanotubes (CNTs) are one of the key materials in the field of nanotechnology. It is considered that CNTs have excellent properties of electrical conduction, tensile strength, and thermal conduction. CNTs have been studied scientifically and expected for practical applications.^{1–19} However, their properties are not well understood yet because of the difficulty in nanomeasurements. A CNT composed of a single graphene sheet rolled up into a cylinder is called a single-walled carbon nanotube (SWNT). Multi-walled carbon nanotubes (MWNTs) consist of multilayers of graphene sheet. The physical property of SWNTs can be either metallic or semiconducting, depending on both their diameter and chirality.

Thermal conductivity is one of the most interesting properties of CNTs. There are many studies of thermal conductivity, as shown in Table I.^{2–17} Some researchers reported thermal conductivities on the same order as those of graphite ($100–500 \text{ W}\cdot\text{m}^{-1}\cdot\text{K}^{-1}$) and some other researchers reported thermal conductivities as high as that of diamond (larger than $10000 \text{ W}\cdot\text{m}^{-1}\cdot\text{K}^{-1}$). Thus, the reported thermal conductivities are scattered over a wide range.

Recently, “supergrowth” CNTs have been synthesized by water-assisted Chemical Vapor Deposition (CVD).^{20,21} Supergrowth SWNTs are of high purity. They form a SWNT forest as long as a millimeter-scale length, as shown in Fig. 1(a).²⁰ Because of this millimeter-scale length, conventional techniques of measuring the physical properties of bulk materials can be applicable to measure physical properties of the supergrowth SWNT forests.

We tried to measure the thermal diffusivity of supergrowth SWNT forests using the laser flash method, which is a well-established, reliable, and standard method of measuring the thermal diffusivity of solids above room temperature.²² The typical specimen for this method is a disk sample of millimeter-scale thickness. The supergrowth SWNT forest samples are large enough to be measured by

Table I. Literature thermal conductivities of CNT at room temperature.

Author	CNT	Thermal conductivity ($\text{W}\cdot\text{m}^{-1}\cdot\text{K}^{-1}$)	Method
Hone <i>et al.</i> ²⁾	SWNT (crystalline rope)	35	Experimental
Hone <i>et al.</i> ³⁾	SWNT (array film)	250	Experimental
Panzer <i>et al.</i> ⁴⁾	SWNT (array film)	~8	Experimental
Fujii <i>et al.</i> ⁵⁾	SWNT (single tube)	1500	Experimental
Yu <i>et al.</i> ⁶⁾	SWNT (single tube)	2000–10000	Experimental
Pop <i>et al.</i> ⁷⁾	SWNT (single tube)	~3500	Experimental
Maruyama <i>et al.</i> ⁸⁾	SWNT	200–400	Numerical
Cummings <i>et al.</i> ⁹⁾	SWNT	1000–3000	Numerical
Mingo <i>et al.</i> ¹⁰⁾	SWNT	5000	Numerical
Shiomi <i>et al.</i> ¹¹⁾	SWNT	200–1000	Numerical
Yang <i>et al.</i> ¹²⁾	MWNT (array film)	15	Experimental
Hu <i>et al.</i> ¹³⁾	MWNT (array film)	75	Experimental
Yi <i>et al.</i> ¹⁴⁾	MWNT (bundles)	25	Experimental
Kim <i>et al.</i> ¹⁵⁾	MWNT (single bundle)	3000	Experimental
Choi <i>et al.</i> ¹⁶⁾	MWNT (single tube)	650–830	Experimental
Choi <i>et al.</i> ¹⁷⁾	MWNT (single tube)	280–320	Experimental

this method. When thermal diffusivity is measured by the laser flash method, it is preferable that the material is optically nontransparent and dark-colored (ideally black) in order to absorb the light of the pulse heating in a thin surface and to obtain high emissivity for the radiative detection of the transient temperature change after the pulse heating. Supergrowth SWNT forests also satisfy this condition.

Self-standing samples of as-grown supergrowth SWNT forest removed from silicon substrates of about 1 mm in thickness were measured. The measurement was carried out along the thickness direction of the samples at room temperature. The solid of the supergrowth SWNT forest was also measured in the same way. The temperature dependence of the thermal diffusivity of as-grown supergrowth SWNT forest was measured in the range of temperatures between

*E-mail address: m-akoshima@aist.go.jp

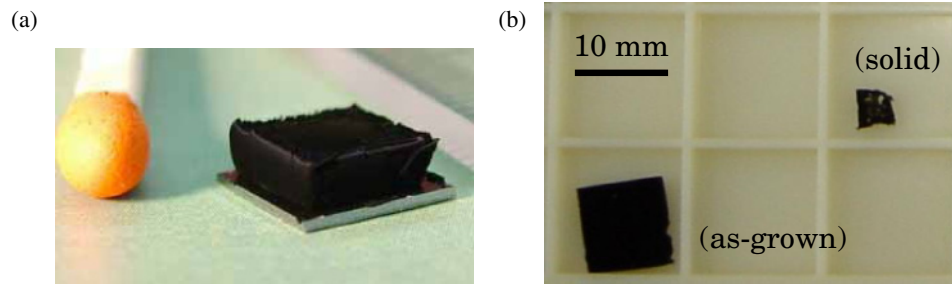

Fig. 1. (Color online) (a) Supergrowth carbon nanotube synthesized on silicon substrate²⁰ and (b) measured self-standing supergrowth SWNT forest samples removed from silicon substrate.

room temperature and about 1000 K. In order to examine the performance of the measurement instrument, the thermal diffusivity of an isotropic graphite sample was also measured. The isotropic graphite is a reference material for the laser flash method produced by the National Metrology Institute of Japan (NMIJ).^{22–25}

2. Experimental Procedure

2.1 Samples

The supergrowth SWNT forests were synthesized on $10 \times 10 \text{ mm}^2$ square silicon substrates by water-assisted CVD.²⁰ The supergrowth SWNT forests can be easily removed from their substrates with, for example, a razor blade.²⁰ The supergrowth SWNT forests removed from the substrate keep their shape and are self-standing. According to the movie in ref. 20, the self-standing as-grown supergrowth SWNT forest samples for this study were prepared. One of the as-grown samples is shown in Fig. 1(b). The self-standing sample is typically 10×10 or $5 \times 5 \text{ mm}^2$ square and about 1 mm in thickness. The thickness, as the length, of the sample was measured using a linear gauge calibrated by some block gauges. There is large distribution of thickness in a sample. We determined the thickness of a sample as the average of the measured values at five different points in the sample. The typical maximum deviation of the thickness of a sample was estimated to be about $30 \mu\text{m}$ for the as-grown samples.

The as-grown supergrowth SWNT forests are soaked in liquid and dried to make a solid of supergrowth SWNTs.²¹ The SWNTs approach each other owing to the surface tension of the liquid and Van der Waals force between carbon nanotubes. The solid of supergrowth SWNT forest has a 15-fold density compared with that of as-grown supergrowth SWNT forest. Solid samples of about 1 mm thickness and 5×5 or $3 \times 3 \text{ mm}^2$ square were prepared for the thermal diffusivity measurement. The maximum deviation of the thickness of a sample was estimated to be about $20 \mu\text{m}$ for the solid samples.

We have also prepared isotropic graphite samples of 10 mm in diameter and 0.4, 0.8, 1.0, and 2.0 mm in thickness to verify our measurement system. The samples were made of isotropic graphite of the same grade, which has been established as the reference material “NMIJ RM-1201”. NMIJ RM-1201 is a reference material for the laser flash method produced by NMIJ.²⁵ The isotropic graphite samples used in this study were prepared similarly to the reference material.

2.2 Measurement method

The laser flash method²⁶ is a popular method for measuring the thermal diffusivity of solid materials. The surface of the sample is pulsed-heated by a uniform laser beam and subsequent heat diffusion is observed as a change in rear-surface temperature. Heat diffusion time is determined from the time dependence curve of rear-surface temperature. Thermal diffusivity is calculated as,

$$\alpha(T) = \frac{d^2}{\tau_0}, \quad (1)$$

where, α is the thermal diffusivity, T is the temperature where the measurement is carried out, d is the thickness of sample, and τ_0 is the heat diffusion time. This method is very simple because it is a one-dimensional heat diffusion phenomenon. It is easy to check the reliability of measurement result because of this simplicity.

Figure 2 shows a schematic diagram of our laser flash measurement system. The sample is held at a stable temperature in a vacuum chamber. The surface of the sample is uniformly pulsed-heated by a Nd-YAG laser beam through an optical fiber with a mode mixer.²⁷ After the pulsed heating, the temperature change of the rear-surface of the sample is observed by a fast infrared radiometer, which has the absolute temperature scale around room temperature.²⁷ The thermocouple to measure temperature of the sample before the pulsed heating is calibrated.²² We particularly optimized our measurement system and evaluate uncertainty in accordance with “Guide to the Expression of Uncertainty in Measurement” (GUM)²⁸ and ISO 17025²⁹ as the standard measurement method.^{22,24}

2.3 Measurements

The thermal diffusivities of the as-grown and solid supergrowth SWNT forest samples are measured by the laser flash method. The measurement is carried out along the thickness direction of each sample. The carbon materials are preferred for measuring thermal diffusivity using the laser flash method because it has high absorbance on a laser beam for pulsed heating and a low transmittance on the wavelength of the infrared radiometer for temperature change observation of the laser flash instruments. Then the CNT samples can be measured even without coating. The measured temperature history curves show a small signal attributed to the transmitted laser beam, as shown in Fig. 3. The curve also shows a good agreement with a function for a homogeneous dense material. This indicates that a large part

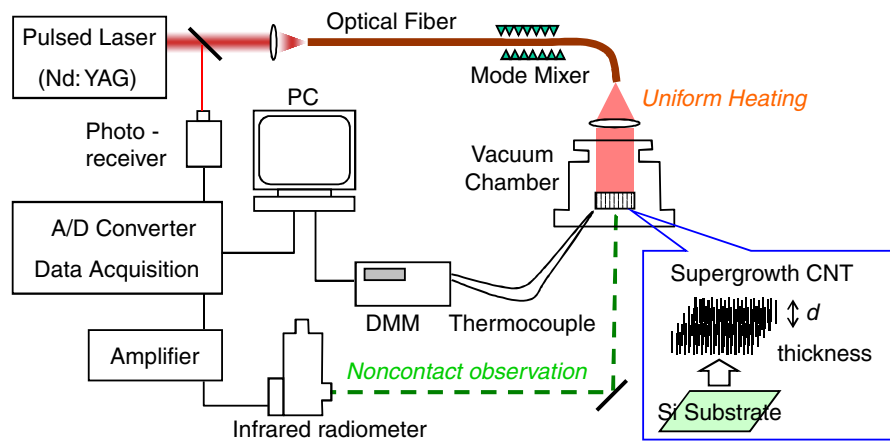

Fig. 2. (Color online) Schematic diagram of the laser flash measurement system for the supergrowth SWNT forest samples. The measurement was carried out along the thickness direction.

of the beam is absorbed near the surface of the sample although the SWNT forest samples are not dense materials. Thermal diffusivity will be overestimated when there is some penetration of the laser beam for pulsed heating according to eq. (1). This means that the thermal diffusivity result in this study is the maximum limit of the SWNT forest samples.

We measured the thermal diffusivity of the self-standing as-grown supergrowth SWNT forest samples from room temperature to about 1000 K. The measurement is carried out along the thickness direction of samples in vacuum. The measurement was repeated more than three times with a fixed pulsed heating energy at each temperature. Thermal diffusivity is calculated as the average from the measured data at all temperatures.

The thermal diffusivity along the length of the solid of supergrowth SWNT forest was measured by the laser flash method at room temperature in air. The measurement was carried out with varying pulsed heating energy. The thermal diffusivity is obtained as a value extrapolated to zero in thermal diffusivity plotted against the amplitude of the signal corresponding to pulsed heating energy.^{22,23)}

The isotropic graphite samples are measured by the standard measurement procedure with varying pulsed heating energy.²²⁾ The uncertainty of the thermal diffusivity at room temperature is about 4% with a coverage factor $k = 2$ in the case of isotropic graphite.²⁴⁾ The uncertainty is a combination of uncertainty factors attributed to thickness, heat diffusion time, temperature, data analysis, and repeatability of the measurements.²⁴⁾

The measured temperature history curves were analyzed using “CFP32 for Windows”.³⁰⁾ CFP32 for Windows is a data-analysis software for the laser flash method developed by NMIJ.

3. Results and Discussion

Figure 3(a) shows an example of the measured temperature history curve of as-grown supergrowth SWNT forest sample No. B27 at room temperature. Figure 3(b) shows an example of measured temperature history curve of the solid sample of the supergrowth SWNT forest. Both signals show good S/N ratios. The supergrowth SWNT forest sample is easy to measure using our system. There is a small peak at the time

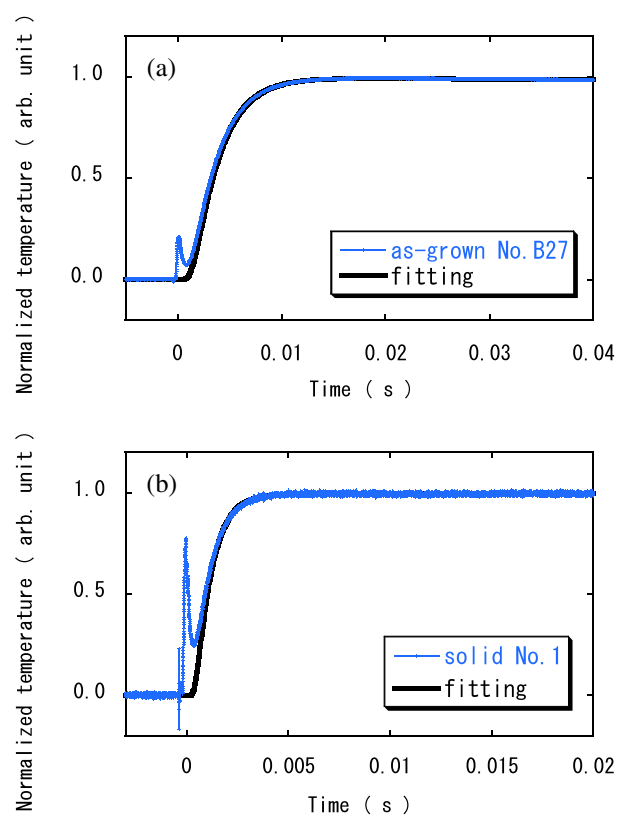

Fig. 3. (Color online) Temperature history curve at room temperature of (a) as-grown supergrowth SWNT forest sample No. B27 and (b) solid No. 1.

of the pulsed heating, as shown in Fig. 3. It is a signal of the laser beam through a sample. The laser beam partially goes through the sample, since SWNTs are not closely packed in the forest. Analysis was mainly performed over the region after the half-rise time, since the initial part of the temperature history curve might be distorted by the effect of stray light. The temperature history curve shows a good agreement with the theoretical curve for homogeneous and dense materials. This indicates that a large part of the beam is absorbed near the surface of the sample although the SWNT forest samples are not dense materials. When there is some penetration of the laser beam for pulsed heating, the

Table II. Thermal diffusivities measured by the laser flash method.

Material	Sample	Length (mm)	Thermal diffusivity α ($\text{m}^2 \cdot \text{s}^{-1}$)
As-grown supergrowth CNT	G03	0.700	7.5×10^{-5}
	F00	1.468	7.7×10^{-5}
	B27	1.287	6.4×10^{-5}
	B36	0.884	4.7×10^{-5}
	B38	0.850	6.6×10^{-5}
Solid supergrowth CNT	No. 1	0.600	7.8×10^{-5}
	No. 2	0.997	1.0×10^{-4}
Isotropic graphite ²²⁾	—	—	$\sim 1.0 \times 10^{-4}$

effective sample thickness becomes smaller than the sample thickness. Then the measured thermal diffusivity becomes larger than the intrinsic value, that is, it becomes the maximum limit of the SWNT forest samples. The measurement of a SWNT forest sample under the same conditions was repeated more than three times. The variation in thermal diffusivity attributed to the repeatability of measurement is about 3% as the standard deviation for a SWNT forest sample.

The results obtained at room temperature are summarized in Table II. The thermal diffusivities of the as-grown supergrowth SWNT forest samples are from 4.7×10^{-5} to $7.7 \times 10^{-5} \text{ m}^2 \cdot \text{s}^{-1}$. The average is $6.6 \times 10^{-5} \text{ m}^2 \cdot \text{s}^{-1}$. The solid samples of the supergrowth SWNT forest show thermal diffusivities as 7.8×10^{-5} and $1.0 \times 10^{-4} \text{ m}^2 \cdot \text{s}^{-1}$, the average is $8.9 \times 10^{-5} \text{ m}^2 \cdot \text{s}^{-1}$. These measured thermal diffusivities are of about the same order independent of the SWNT forests being as-grown or solid. Therefore we considered that the values are intrinsic thermal diffusivities of the supergrowth SWNT forests along the length. Because of the penetration of the laser beam and the transmission of the thermal radiation of voids in the sample, the effective heat diffusion length is smaller than the sample thickness. This effect reduces heat diffusion time and gives a larger apparent thermal diffusivity. Then the thermal diffusivities in Table II denote the upper limits for all samples, in accordance with eq. (1).

In order to verify our measurement system, we measure isotropic graphite samples. These isotropic graphite samples are IG-110 specimens prepared similarly to the reference material NMIJ RM-1201 for the laser flash measurement produced by NMIJ.²⁵⁾ NMIJ RM-1201 has inherent thermal diffusivity as the absolute value from 300 to 1500 K with uncertainties of 5 to 7% (coverage factor $k = 2$). This uncertainty of the reference material is a combination of the uncertainty factors attributed to thickness, heat diffusion time, temperature, data analysis, repeatability of the measurements, and heterogeneity of the lot. The isotropic graphite samples for this study are 10 mm in diameter and 0.4, 0.8, 1.0, and 2.0 mm in thickness. They were prepared from adjacent segments of a block of isotropic graphite. The thermal diffusivities of these specimens are calculated using measured data with different pulsed heating energies. Inherent thermal diffusivity independent of sample thickness and pulsed heating energy is determined by extrapolating heating energy to zero, as shown in Fig. 4. Then our measurement system and procedure are optimized. The

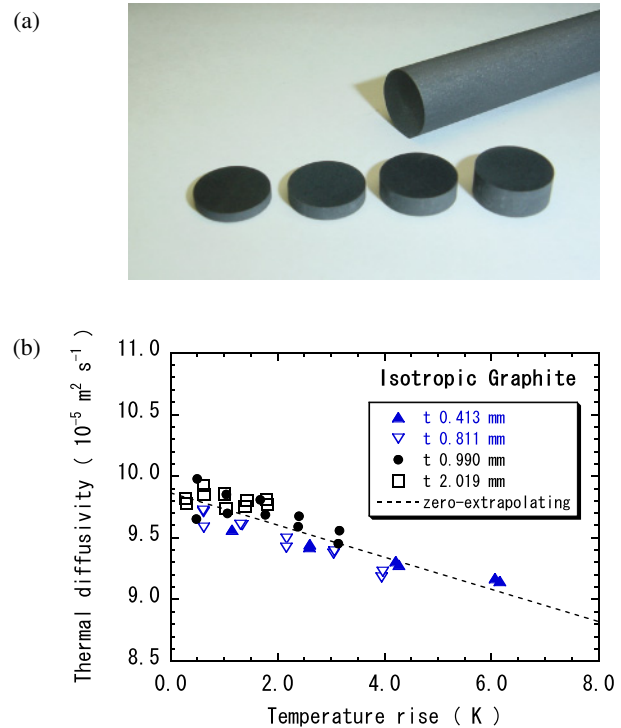

Fig. 4. (Color online) (a) An example of isotropic graphite samples, (b) inherent thermal diffusivity at room temperature of the isotropic graphite.

inherent thermal diffusivities of the isotropic graphite samples at room temperature are shown in Table II. The uncertainty of the thermal diffusivity measurement of isotropic graphite is 5% at room temperature similar to that of NMIJ RM-1201. Based on this verification, the measurement system can measure thermal diffusivity under the conditions used in this study within 5% uncertainty ($k = 2$).

In the case of the supergrowth SWNT forest samples, there is large distribution of thickness in each sample. The typical deviation of the thickness of a sample was estimated to be about 30 μm for the as-grown samples and about 20 μm for the solid samples. These deviations are 3 and 2% as thickness uncertainty in the case of 1-mm-thick samples. Since thermal diffusivity is proportional to the square of thickness, as shown in eq. (1), uncertainty propagation becomes double. Then the uncertainties of thermal diffusivity attributed to thickness are 6 and 4% for the as-grown and solid samples of the SWNT forest, respectively. The uncertainty due to measurement including conditions and analysis is empirically about 1% at room temperature in the case of carbon material.²⁴⁾ The temperature uncertainty is about 1% at room temperature.²⁴⁾ According to these uncertainty factors, the combined standard uncertainties of the thermal diffusivities of the SWNT forest samples are estimated to be about 7 and 5% with a coverage factor $k = 1$ for the as-grown and solid SWNT forest samples, respectively. Then the uncertainties of the thermal diffusivities of the as-grown and solid supergrowth SWNT forest samples are 14 and 10%, respectively, with a coverage factor $k = 2$. Note that there are few reports on the uncertainty of measurement results for CNTs. This study has an advantage in terms of high reliability.

We tried to estimate the thermal conductivity of the supergrowth SWNT forest samples. Generally, the thermal conductivity λ is a function of the thermal diffusivity α , the specific heat capacity c_p and the density ρ as follows:

$$\lambda = \alpha \cdot c_p \cdot \rho. \quad (2)$$

The specific heat capacity c_p is quoted from that of graphite, $710 \text{ J} \cdot \text{kg}^{-1} \cdot \text{K}^{-1}$ at room temperature, since the CNTs and isotropic graphite consist of a six-membered carbon ring. The weight of the as-grown supergrowth SWNT forest sample, whose size is $10 \times 10 \times 1 \text{ mm}^3$ is about 4 mg. Then the bulk density of the sample is estimated to be about $40 \text{ kg} \cdot \text{m}^{-3}$. This density is about 3/100 that of isotropic graphite. As mentioned in previous page, the average measured thermal diffusivity is $6.6 \times 10^{-5} \text{ m}^2 \cdot \text{s}^{-1}$. Then the thermal conductivity is calculated to be $1.9 \text{ W} \cdot \text{m}^{-1} \cdot \text{K}^{-1}$ from eq. (2).

Note that the supergrowth SWNTs samples are consist of SWNT forests. The typical diameter of SWNTs in the sample is 3 nm.³¹⁾ The volume of a cylinder, with a diameter of 3 nm and a length of 1 mm, is calculated to be $7.1 \times 10^{-21} \text{ m}^3$. The number of SWNTs for these forest samples, which is $10 \times 10 \times 1 \text{ mm}^3$ in size is about 5×10^{11} .³¹⁾ The weight of a SWNT is estimated to be $8 \times 10^{-12} \text{ mg}$ by dividing the weight of the whole sample by the number of SWNTs. Then the apparent density of a SWNT is calculated to be about $1100 \text{ kg} \cdot \text{m}^{-3}$ by dividing the weight of a SWNT by the volume of a 3 nm diameter cylinder. Using these values and eq. (2), the thermal conductivity of a SWNT is calculated to be about $52 \text{ W} \cdot \text{m}^{-1} \cdot \text{K}^{-1}$. Assuming that the skin of the carbon nanotube is 3.4 \AA , the apparent density of a SWNT is calculated to be about $2500 \text{ kg} \cdot \text{m}^{-3}$ by dividing the weight of a SWNT by the volume of the skin of a 3 nm diameter cylinder. From eq. (2), the thermal conductivity of a SWNT is calculated to be about $120 \text{ W} \cdot \text{m}^{-1} \cdot \text{K}^{-1}$. The thermal conductivity calculated from the measured thermal diffusivity of the as-grown supergrowth SWNT forest sample shows the same order of values as those in refs. 2–4 and 8, as shown in Table I.

The density of the solid of the supergrowth SWNT forest is about 15-fold that of the as-grown sample. Thermal conductivity was also calculated to be 38, 1042, and $2369 \text{ W} \cdot \text{m}^{-1} \cdot \text{K}^{-1}$ using the average of the measured thermal diffusivity of $8.9 \times 10^{-5} \text{ m}^2 \cdot \text{s}^{-1}$ and eq. (2) in the case of the solid of the supergrowth SWNT forest samples.

As stated above, the thermal conductivity calculated using eq. (2) changes proportionally to the density used for calculation. The definition of the density of CNTs is an important subject in the discussion of the thermal conductivity of CNTs. On the other hand, the thermal diffusivity is independent of the density of the sample. It just depends on thermophysical properties of SWNTs. This indicates that it is hard to compare thermal conductivities calculated using eq. (2) involving thermal diffusivity and density with the thermal conductivities shown in Table I. We consider that the thermal diffusivity measured in this study is an intrinsic value for the SWNT forest samples. However, it may not represent the thermal conductivity of a CNT. This is because the supergrowth SWNTs form forest and they may not stand-alone CNTs.

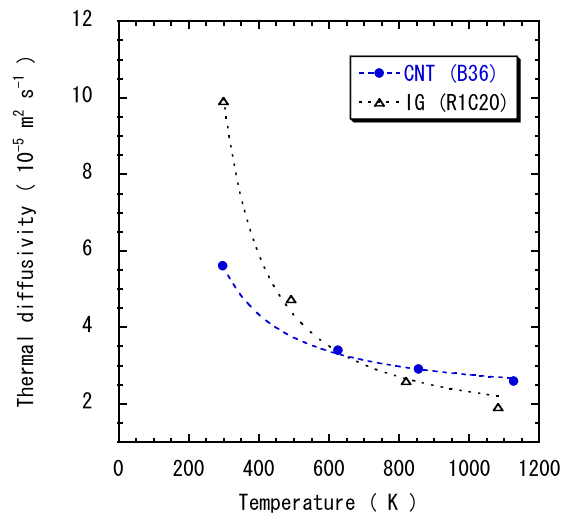

Fig. 5. (Color online) Temperature dependence of thermal diffusivities of a supergrowth SWNT forest sample (No. B36) and an isotropic graphite sample (IG No. R1C20) measured by the laser flash method.

Figure 5 shows the temperature dependence of the thermal diffusivity of the as-grown supergrowth SWNT forest sample B36 from room temperature to about 1000 K. For the sample B36, the thermal diffusivity at room temperature after the measurement at 1000 K increased by less than 5% compared with the value before the measurement at 1000 K. However, the change is negligible since the uncertainty of the supergrowth SWNT forest sample is more than 10%. Simply, thermal conductivity is proportional to $\exp(\theta_D/bT)$ related to phonon scattering when $T < \theta_D$.³²⁾ Here, θ_D is the Debye temperature and b is a constant. The Debye temperature of isotropic graphite is above 2000 K.³³⁾ We consider approximately that temperature dependence with $\exp(\theta_D/bT)$ is also predominant for thermal diffusivity in the temperature range in accordance with eq. (2). The thermal diffusivity of isotropic graphite shows a good agreement with the temperature dependence being proportional to $\exp(\theta_D/bT)$, as shown in Fig. 5. We try to fit the function of the thermal diffusivities of the supergrowth SWNT forest sample by the least-squares method. It was found that the behavior of the CNT sample seems similar to that of isotropic graphite, as shown in Fig. 5. It may be possible to discuss the temperature dependence of the thermal diffusivity of CNTs in detail when we have more measurement data and information on the Debye temperature of CNTs. The thermal conductivity of SWNTs above room temperature has been reported.⁷⁾ Our measurement result shows the same trend with increasing temperature. Pop *et al.* reported a small decrease in thermal conductivity steeper than $1/T$ from their measurement result and results obtained using an analytical model.⁷⁾

It is found in this study that thermal diffusivity of the supergrowth SWNT forest sample is on the same order as that of isotropic graphite. The thermal conductivity estimated from our result is on the same order as those reported in refs. 2–4 and 8, as shown in Table I. The supergrowth SWNT forests are composed of a SWNT bundle array. It seems that the thermal conductivities of CNT bundles and arrays are smaller than that of single CNTs, as shown in

Table I. There is a possibility that physical properties of nanotube bundles and arrays are different from those of a single nanotube. In general, thermal diffusivity and thermal conductivity become smaller owing to some defects. It is undeniable that supergrowth SWNT forests may have inclusion defects because they are very long CNTs. More experimental studies should be carried out in order to investigate the thermophysical properties of CNTs systematically.

4. Conclusions

We have measured the thermal diffusivity of supergrowth SWNT forest samples using the laser flash method. The as-grown SWNT forest samples are self-standing even if removed from the silicon substrate. They are 5×5 or $10 \times 10 \text{ mm}^2$ square in shape and about 1 mm in thickness. The solid samples of the supergrowth SWNT forest is 5×5 or $3 \times 3 \text{ mm}^2$ square in shape and about 1 mm in thickness. Measurements are carried out along the thickness direction of the sample using the laser flash measurement system verified by the measurement of the properties of isotropic graphite supplied as the reference material by NMIJ.

The thermal diffusivities of the as-grown SWNT forest samples measured at room temperature are from 4.7×10^{-5} to $7.7 \times 10^{-5} \text{ m}^2 \cdot \text{s}^{-1}$. The solid SWNT forest samples showed thermal diffusivities as 7.8×10^{-5} and $1.0 \times 10^{-4} \text{ m}^2 \cdot \text{s}^{-1}$ at room temperature.

The temperature dependence of the as-grown SWNT forest samples was measured from room temperature to 1000 K. The thermal diffusivity of the sample changed in the range from 2.0×10^{-5} to $6.0 \times 10^{-5} \text{ m}^2 \cdot \text{s}^{-1}$. The thermal diffusivities of the supergrowth SWNT forest sample are on the same order as those of isotropic graphite.

Acknowledgment

The author (M.A.) would like to thank J. Shiomi (University of Tokyo) for helpful advice.

- 1) S. Iijima: *Nature* **354** (1991) 56.
- 2) J. Hone, M. Whiteny, C. Piskoti, and A. Zettl: *Phys. Rev. B* **59** (1999) R2514.
- 3) J. Hone, M. C. Llaguno, N. M. Nemes, A. T. Johnson, J. E. Fischer, D. A. Walters, M. J. Casavant, J. Schmidt, and R. E. Smalley: *Appl. Phys. Lett.* **77** (2000) 666.

- 4) M. A. Panzer, G. Zhang, D. Mann, X. Hu, E. Pop, H. Dai, and K. E. Goodson: *J. Heat Transfer* **130** (2008) 052401.
- 5) M. Fujii, X. Zhang, H. Xie, H. Ago, K. Takahashi, T. Ikuta, H. Abe, and T. Shimizu: *Phys. Rev. Lett.* **95** (2005) 65502.
- 6) C. Yu, L. Shi, Z. Yao, D. Li, and A. Majumdar: *Nano Lett.* **5** (2005) 1842.
- 7) E. Pop, D. Mann, Q. Wang, K. Goodson, and H. Dai: *Nano Lett.* **6** (2006) 96.
- 8) S. Maruyama: *Nanoscale Microscale Thermophys. Eng.* **7** (2003) 41.
- 9) A. Cummings, M. Osman, D. Srivastava, and M. Menon: *Phys. Rev. B* **70** (2004) 115405.
- 10) N. Mingo and D. A. Broido: *Nano Lett.* **5** (2005) 1221.
- 11) J. Shiomi and S. Maruyama: *Jpn. J. Appl. Phys.* **47** (2008) 2005.
- 12) D. J. Yang, Q. Zhang, G. Chen, S. F. Yoon, J. Ahn, S. G. Wang, Q. Zhou, Q. Wang, and J. Q. Li: *Phys. Rev. B* **66** (2002) 165440.
- 13) X. J. Hu, A. A. Padilla, J. Xu, T. S. Fisher, and K. E. Goodson: *J. Heat Transfer* **128** (2006) 1109.
- 14) W. Yi, L. Lu, Zhang Dian-lin, Z. W. Pan, and S. S. Xie: *Phys. Rev. B* **59** (1999) R9015.
- 15) P. Kim, L. Shi, A. Majumdar, and P. L. McEuen: *Phys. Rev. Lett.* **87** (2001) 215502.
- 16) T. Y. Choi, D. Poulidakos, J. Tharian, and U. Sennhauser: *Appl. Phys. Lett.* **87** (2005) 13108.
- 17) T. Y. Choi, D. Poulidakos, J. Tharian, and U. Sennhauser: *Nano Lett.* **6** (2006) 1589.
- 18) T. Ando, H. Matsumura, and T. Nakanishi: *Physica B* **323** (2002) 44.
- 19) T. Nakanishi, A. Bachtold, and C. Dekker: *Phys. Rev. B* **66** (2002) 73307.
- 20) K. Hata, D. N. Futaba, K. Mizuno, T. Namai M. Yumura, and S. Iijima: *Science* **306** (2004) 1362.
- 21) D. N. Futaba, K. Hata, T. Yamada, K. Mizuno, M. Yumura, and S. Iijima: *Phys. Rev. Lett.* **95** (2005) 56104.
- 22) M. Akoshima and T. Baba: *Int. J. Thermophys.* **26** (2005) 151.
- 23) M. Akoshima and T. Baba: *Thermal Conductivity 28/Thermal Expansion 16, Proc. 28th Int. Thermal Conductivity Conf./16th Int. Thermal Expansion Symp.* (DEStech Publications, Lancaster, PA, 2006) p. 497.
- 24) M. Akoshima and T. Baba: *Int. J. Thermophys.* **27** (2006) 1189.
- 25) M. Akoshima and T. Baba: submitted to *Int. J. Thermophys.*
- 26) W. J. Parker, R. J. Jenkins, C. P. Butler, and G. L. Abbott: *J. Appl. Phys.* **32** (1961) 1679.
- 27) T. Baba and A. Ono: *Meas. Sci. Technol.* **12** (2001) 2046.
- 28) ISO/IEC Guide 98:1995 (1995).
- 29) ISO/IEC 17025:2005 (2005).
- 30) <http://www.nmij.jp/mprop-stats/thermophys/homepage/research/cfp32/index.html>
- 31) D. N. Futaba, K. Hata, T. Namai, T. Yamada, K. Mizuno, Y. Hayamizu, M. Yumura, and S. Iijima: *J. Phys. Chem. B* **110** (2006) 8035.
- 32) J. M. Ziman: *Electrons and Phonons* (Clarendon Press, Oxford, U.K., 2001) p. 288.
- 33) B. T. Kelly: *Physics of Graphite* (Applied Science Publishers, London, 1981) p. 148.