



## Flash Diffusivity Technique Applied to Individual Fibers

**Inversion of spatially and temporally resolved temperature measurements yields thermal-diffusivity maps.**

*Lyndon B. Johnson Space Center, Houston, Texas*

A variant of the flash diffusivity technique has been devised for determining the thermal diffusivities, and thus the thermal conductivities, of individual aligned fibers. The technique is intended especially for application to nanocomposite fibers, made from narrower fibers of polyphenylene benzobisthiazole (PBZT) and carbon nanotubes. These highly aligned nanocomposite fibers could exploit the high thermal conductivities of carbon nanotubes for thermal-management applications.

In the flash diffusivity technique as practiced heretofore, one or more heat pulse(s) is (are) applied to the front face of a plate or disk material specimen and the resulting time-varying temperature on the rear face is measured. Usually, the

heat pulse is generated by use of a xenon flash lamp, and the variation of temperature on the rear face is measured by use of an infrared detector. The flash energy is made large enough to produce a usefully high temperature rise on the rear face, but not so large as to significantly alter the specimen material. Once the measurement has been completed, the thermal diffusivity of the specimen is computed from the thickness of the specimen and the time dependence of the temperature variation on the rear face.

Heretofore, the infrared detector used in the flash diffusivity technique has been a single-point detector, which responds to a spatial average of the thermal radiation from the rear specimen surface. Such a detector cannot distin-

guish among regions of differing diffusivity within the specimen. Moreover, two basic assumptions of the thermal-diffusivity technique as practiced heretofore are that the specimen is homogeneous and that heat flows one-dimensionally from the front to the rear face. These assumptions are not valid for an inhomogeneous (composite) material.

In the present variant of the flash diffusivity technique, one uses an infrared electronic camera fitted with a microscope lens to record the spatial as well as the temporal variations in thermal radiation emitted from the rear face of the specimen (see figure). In the recorded image of a composite-material specimen, it is possible to distinguish between

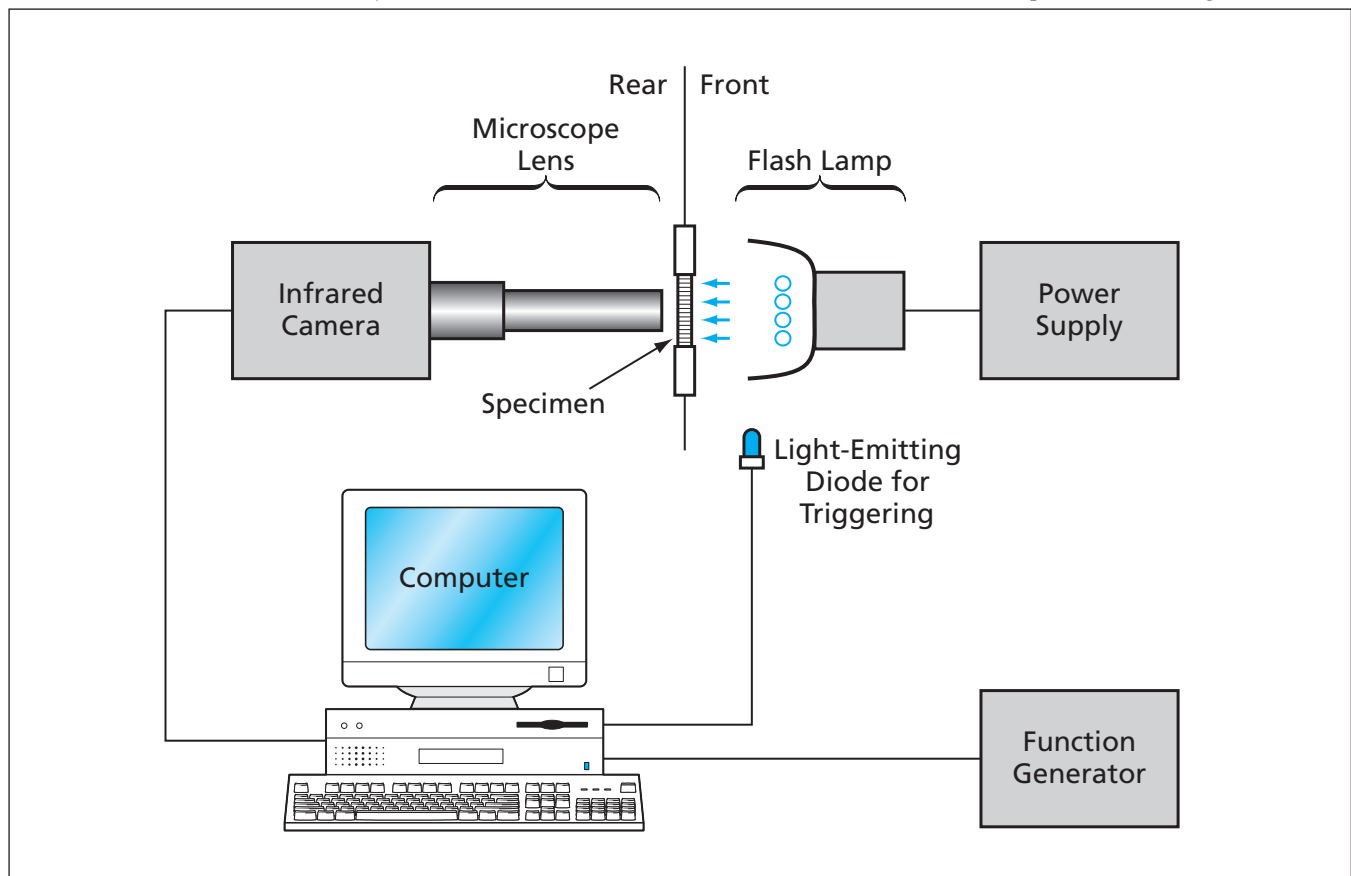

An Infrared Camera With Microscope Lens measures the spatial as well as temporal variations of temperature on the rear face of a specimen that has been flash-heated on its front face.

individual fibers, or between a fiber and the surrounding matrix material. Hence, it is possible to measure the rear-face temperature variations of individual fibers. These variations can be correlated with predictions of a computational model of heat transfer in the composite specimen to obtain a diffusivity map of the specimen.

The technique was demonstrated on a specimen containing pure PBZT fibers, one nanocomposite PBZT/carbon-nanotube fiber, and one copper

fiber mounted longitudinally in an epoxy matrix. The copper fiber, having known thermal conductivity, was included for qualitative comparison. The temperature transients of the pure PBZT fibers were not distinguishable from that of the matrix, and the thermal diffusivity of the matrix and PBZT fibers was found to be  $0.0032 \text{ cm}^2/\text{s}$ . The thermal diffusivity of the PBZT/carbon-nanotube composite fiber was found to be  $0.049 \text{ cm}^2/\text{s}$ ; the true bulk diffusivity of the PBZT/car-

bon-nanotube composite could be higher than the value computed from the measurements because the heat-transfer model used in the computations does not account for thermal coupling between the fibers and the matrix.

*This work was done by Brian Mayeaux, Leonard Yowell of Johnson Space Center, and Hsin Wang of Oak Ridge National Laboratory. For further information, contact the Johnson Innovative Partnerships Office at (281) 483-3809. MSC-23609*

## System for Thermal Imaging of Hot Moving Objects

**This advanced ratio-intensity thermography system has numerous potential uses.**

*Langley Research Center, Hampton, Virginia*

The High Altitude/Re-Entry Vehicle Infrared Imaging (HARVII) system is a portable instrumentation system for tracking and thermal imaging of a possibly distant and moving object. The HARVII is designed specifically for measuring the changing temperature distribution on a space shuttle as it reenters the atmosphere. The HARVII system or other systems based on the design of the HARVII system could also be used for such purposes as determining temperature distributions in fires, on volcanoes, and on surfaces of hot models in wind tunnels. In yet another potential application, the HARVII or a similar system would be used to infer atmospheric pollution levels from images of the Sun acquired at multiple wavelengths over regions of interest.

The HARVII system includes the Ratio Intensity Thermography System (RITS) and a tracking subsystem that keeps the RITS aimed at the moving object of interest. The subsystem of primary interest here is the RITS (see figure), which acquires and digitizes images of the same scene at different wavelengths in rapid succession. Assuming that the time interval between successive measurements is short enough that temperatures do not change appreciably, the digitized image data at the different wavelengths are processed to extract temperatures according to the principle of ratio-intensity thermography: The temperature at a given location in a scene is inferred from the ratios between or among intensities of infrared radiation from that location at two or more wavelengths. This principle, based on the Stefan-Boltzmann equation for

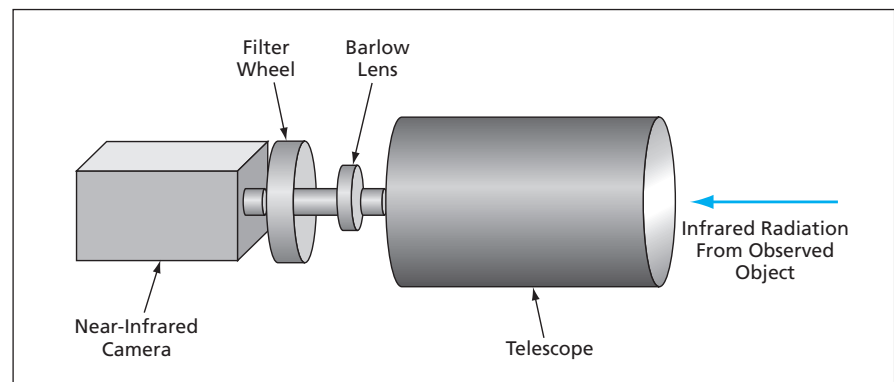

The RITS Acquires Images at Multiple Wavelengths in rapid succession by means of synchronized operation of a filter wheel and near-infrared camera operating at a frame rate of 30 Hz. The design and mode of operation of this system are such that if two wavelengths are used, then a total of 15 pairs of complete images is acquired during 1 second.

the intensity of electromagnetic radiation as a function of wavelength and temperature, is valid as long as the observed body is a gray or black body and there is minimal atmospheric absorption of radiation.

In this particular variant of ratio-intensity thermography, the wavelengths are chosen to be in the near infrared part of the spectrum and are selected to minimize effects of atmospheric absorption. A nearly ideal pair of wavelengths for minimizing effects of atmospheric absorption would be  $1.3$  and  $1.69 \mu\text{m}$ . An additional advantage of this choice of wavelengths is that conventional, high-quality, commercial optics work well at wavelengths below about  $2 \mu\text{m}$ ; if longer wavelengths were chosen, it would be necessary to design and build special infrared optical components.

In practice, it was necessary to choose  $1.55 \mu\text{m}$  as the longer of the two wavelengths because the infrared camera

available at the time of development of the RITS was found not to be usable out to  $1.69 \mu\text{m}$ . In addition, the pass bands of the filters used to select these observation wavelengths were required to be  $10$  to  $20 \text{ nm}$  wide in order to enable the acquisition of sufficiently strong signals. The finite widths of these pass bands contribute to variations of atmospheric effects at different water-vapor levels. The use of three or more wavelengths could enable almost complete correction for these effects. Alternately, if one continued to use two wavelengths, then corrections could be derived from measurements made by a spectrometer aimed at the Sun.

*This work was done by Leonard Weinstein and Jason Hundley of Langley Research Center. For more information, download the Technical Support Package (free white paper) at [www.techbriefs.com/tsp](http://www.techbriefs.com/tsp) under the Physical Sciences category. LAR-16385-1*