

**Development of measurement technique to evaluate
thermal conductivity of thermoelectric Bi₂Te₃
submicron thin films by photothermal radiometry**

H Jitsukawa¹ and Y Nagasaka²

¹*School of Integrated Design Engineering, Keio University, 3-14-1 Hiyoshi, Yokohama,
Kanagawa 223-8522, Japan, E-mail: hitomi@naga.sd.keio.ac.jp*

²*Department of System Design Engineering, Keio University, 3-14-1 Hiyoshi, Yokohama,
Kanagawa 223-8522, Japan, E-mail: nagasaka@sd.keio.ac.jp*

ABSTRACT

The photothermal radiometry, a contact-free and non-destructive measuring technique is possible to simultaneously obtain the thermal conductivity and the thermal diffusivity of samples. We have developed a new apparatus to enhance the modulation frequency of the heating laser up to 100 kHz to measure the thermal conductivity and the thermal diffusivity of thermoelectric submicron thin films. A Bi_2Te_3 bulk sample and Bi_2Te_3 thin films produced with the aid of RF magnetron sputtering on Al_2O_3 substrates were measured with the present apparatus. The measured frequency vs. phase-lag data showed high reproducibility within $\pm 3^\circ$ in the entire frequency range, and the thermal conductivity and the thermal diffusivity of the film were extracted by solving the inverse problem. We found that the thermal conductivity of these thin films 0.8-1.8 μm thickness are less than half that of the corresponding Bi_2Te_3 bulk value of 1.7W/m/K at the minimum. Additionally, the orientations of the films were investigated by X-ray diffraction, and the relationship between the thermal conductivity and the orientation of the film was considered. The thermal conductivity of a poly crystalline film was lower value than that of a highly crystalline film.

KEY WORDS: Bi_2Te_3 ; Peltier cooling device; photothermal radiometry; thermal conductivity; thermal diffusivity; thermoelectric material; thin film.

1. INTRODUCTION

A Peltier cooling system has several beneficial characteristics such as portability, high reliability, temperature controllability and low maintenance, etc. Recently, the thin film Peltier cooling device has been especially expected as a breakthrough to cool the micro-device which generates heat [1, 2]. The performance of the Peltier cooling device is quantified by the figure of merit Z

$$Z = \alpha^2 \sigma_e / \lambda \quad (1)$$

where α is the Seebeck coefficient, σ_e , the electrical conductivity, and λ , the thermal conductivity. The properties of thermoelectric material used for the Peltier device directly affect the cooling efficiency of the device. Therefore, it is desirable to control the thermophysical properties of the thermoelectric material. However, it is difficult to produce a film which has the desirable properties, because the thermophysical properties of thin films vary in the course of film production process, their micro-structure and thickness of the film. Briefly, in case the thin films are used for devices, it becomes more important to evaluate the properties of the films. In the present study, we have developed a new apparatus of the photothermal radiometry (PTR) which is able to modulate the measurement frequency up to 100 kHz to measure the thermal conductivity and the thermal diffusivity of thermoelectric submicron thin films.

This method was previously applied to measure a bulk sample such as the

functionally graded materials (FGMs) [3]. We newly focused attention on measurement at the high modulation frequency range and applied this method to evaluate the thermal conductivity of the thermoelectric thin films. In the present study, we will describe measurement results of the thin films made from Bi₂Te₃.

2. THE PRINCIPLE OF MEASUREMENT

Fig. 1 shows schematically the principle of photothermal radiometry based on a two-layered model (layer 1 and layer 2 mean a film and a substrate, respectively). When a sample is heated by an amplitude-modulated laser beam, the periodic temperature variation caused by heating through absorption generates thermal radiation from the surface of the sample. The temperature wave occurs within the region film thickness is smaller than the thermal diffusion length μ which represents the length where the initial magnitude of the temperature wave is reduced by a 1/e factor. The thermal diffusion length μ expressed as Eq. (2)

$$\mu = \sqrt{a/\pi f} \quad (2)$$

where a is the thermal diffusivity and f , the modulation frequency. By an interference of this temperature wave, the photothermal signals (amplitude and phase-lag) contain information of (i) the thermal conductivity and thermal diffusivity of each layer, (ii) the absorption coefficient and (iii) the thickness of each layer. Therefore, if we measure the photothermal signals as a function of the modulation frequency of the incident laser and

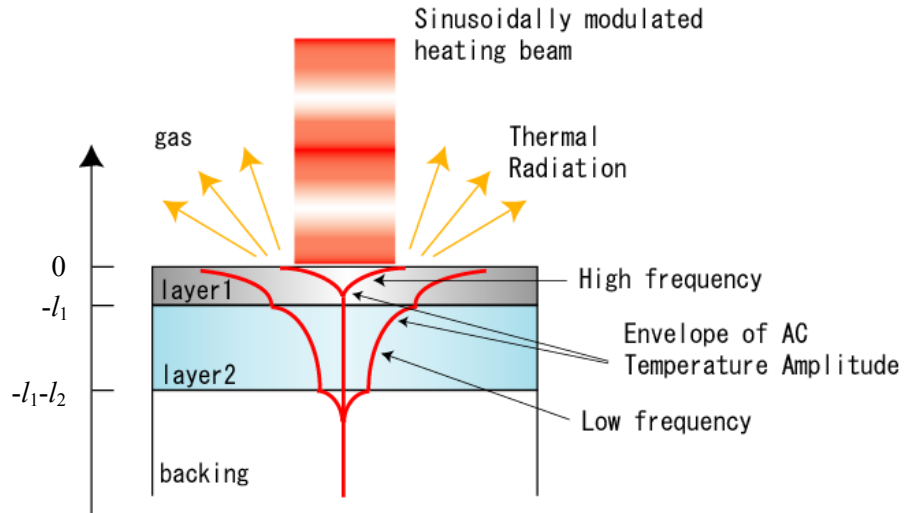

Fig. 1 Principle of the photothermal radiometry.

employ an appropriate data analysis, it is possible to extract the thermal conductivity and the thermal diffusivity of the sample in depth direction. In addition, if we measure at an appropriate frequency range, it is possible to evaluate the thermal conductivity and the thermal diffusivity of a thin film and a multi-layered sample. For example, as the modulated frequency becomes higher, the thermal diffusion length μ becomes shorter. Therefore, the photothermal signals at the higher frequency range contain the information of the thermal conductivity and the thermal diffusivity of the thinner film.

Theoretical description of this method is exactly the same as that of photoacoustic method [2, 3] except for the detection of AC temperature. We developed the two-layered model based on RG theory [4] in order to measure the thermal conductivity and the thermal diffusivity of thin films. The detailed description of the theory has been written in Ref. [3], here only the main equations and the final result will be described.

There are some assumptions in the theory, as follows. Heat conduction is one dimensional within the gas, layer 1, layer 2 and backing. The entire absorbed laser light is instantaneously converted into thermal energy. In addition, it is possible to assume the layer 1 is opaque, since the absorption length of layer 1 is significantly short in comparison with thickness of layer 1. Consequently, the heat conduction equations for two-layered model is expressed by

$$\frac{\partial^2 \Phi_g}{\partial x^2} = \frac{1}{a_g} \frac{\partial \Phi_g}{\partial t} \quad [x \geq 0] \quad (3)$$

$$\frac{\partial^2 \Phi_1}{\partial x^2} = \frac{1}{a_1} \frac{\partial \Phi_1}{\partial t} - \frac{\beta_1 I_0}{2\lambda_1} (1 + \cos \omega t) \exp(\beta_1 x) \quad [-l_1 \leq x \leq 0] \quad (4)$$

$$\frac{\partial^2 \Phi_2}{\partial x^2} = \frac{1}{a_2} \frac{\partial \Phi_2}{\partial t} \quad [-l_1 - l_2 \leq x \leq -l_1] \quad (5)$$

$$\frac{\partial^2 \Phi_b}{\partial x^2} = \frac{1}{a_b} \frac{\partial \Phi_b}{\partial t} \quad [x \leq -l_1 - l_2] \quad (6)$$

where Φ is the complex temperature, β , the absorption coefficient, l , the thickness and I_0 , intensity of heating laser. The subscripts g , 1, 2 and b denote the gas, layer 1, layer 2 and backing, respectively. By solving the heat conduction equations with respect to the AC temperature variation on the basis of appropriate boundary conditions, the amplitude of the complex temperature θ_2 at the sample surface $x = 0$ can be obtained.

The amplitude of complex temperature for two-layered model θ_2 is given by

$$\theta_2 = \frac{\beta_1 I_0}{2\lambda_1(\beta_1^2 - \sigma_1^2)} \times \frac{(B_2 + 1)(\gamma - 1)\exp(\sigma_1 l_1) - (B_2 - 1)(\gamma + 1)\exp(-\sigma_1 l_1) + 2(B_2 - \gamma)\exp(-\beta_1 l_1)}{(B_2 + 1)(g + 1)\exp(\sigma_1 l_1) - (B_2 - 1)(g - 1)\exp(-\sigma_1 l_1)} \quad (7)$$

$$B_2 = b_{12} \times \frac{b_{12} N_2 + b_{1b} M_2}{b_{12} M_2 + b_{1b} N_2} \quad (8)$$

$$M_2 = \exp(\sigma_2 l_2) + \exp(-\sigma_2 l_2) \quad (9)$$

$$N_2 = \exp(\sigma_2 l_2) - \exp(-\sigma_2 l_2) \quad (10)$$

here $\sigma_i = (1 + j)k_i$ denotes the complex wavenumber of the temperature wave in the i -th layer, $k_i = 1/\mu_i$ is the wavenumber in the i -th layer, $\gamma_i = \beta_i/\sigma_i$, $b_{mn} = e_n/e_m$, $g = e_g/e_i$, $e_i = (\lambda_i \rho_i c_i)^{1/2}$, the thermal effusivity of the i -th layer, ρ_i , the density of the i -th layer and c_i , the specific heat capacity of the i -th layer.

The phase-lag of photothermal signals $\Delta\phi$ is given by Eq. (11). For two-layered model, the photothermal signals depend on four parameters including the thermal conductivity, thermal diffusivity and thickness of each layer.

$$\Delta\phi = \tan^{-1} \left[-\frac{\text{Im}(\theta_2)}{\text{Re}(\theta_2)} \right] = F(f : k_1 l_1 / \sqrt{f}, k_2 l_2 / \sqrt{f}, b_{12}, b_{2b}) \quad (11)$$

3. EXPERIMENTAL APPARATUS

As mentioned above, the photothermal radiometry is possible to evaluate the thermal conductivity and the thermal diffusivity of thin films by measuring the phase-lag data at the higher modulation frequency range. Fig. 2 shows the theoretical curve of frequency vs. phase-lag Bi_2Te_3 thin films on Al_2O_3 substrates. As shown in Fig. 2, a theoretical curve of a $1\mu\text{m}$ thin film shifts to the range of high modulation frequency in comparison with a $100\mu\text{m}$ thin film. Therefore, we have developed an apparatus which can modulate the heating frequency up to 100 kHz and it became

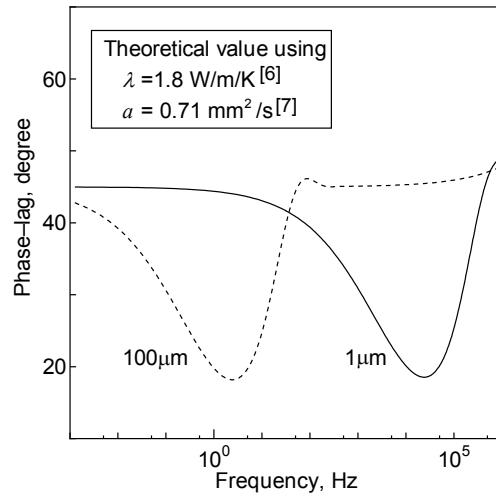

Fig. 2 Theoretical calculation of the effect of the Bi_2Te_3 thin film thickness on the phase-lag.

possible to evaluate the thermal conductivity and the thermal diffusivity of submicron thin films.

The present experimental setup is schematically illustrated in Fig. 3. The heating light source is a 1.2W laser diode (SDL-2370-P2, wavelength 790nm), whose output is coupled to the fiber-optic cable ended with micro lens. The maximum laser power at fiber tip is 800mW. The laser output is modulated by a function generator (HP8116A) operating from 1mHz to 1MHz. The infrared radiation emitted from a sample surface

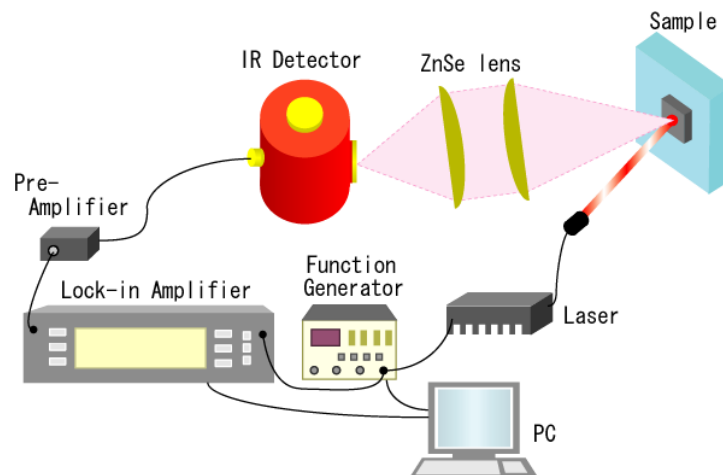

Fig. 3 Experimental apparatus.

is collected and focused onto a detector using two ZnSe lenses through an IR filter. The detector is a liquid-nitrogen-cooled HgCdTe (EG&G Judson J15D14-M204-S01M-60) with an active area of 1mm^2 and spectrally sensitive range of 2-26 μm . The photothermal signal amplified by a pre-amplifier before being sent to a lock-in amplifier (EG&G Instruments 7265).

The diameter of the heating laser has an adequate size to keep one-dimensional theory in the measurement of a sample. When the phase-lag data of a thin film is measured from the low frequency 1Hz to the high frequency 100 kHz, the data contain the thermophysical properties of a thin film, a substrate and a backing. Therefore it is possible to obtain frequency vs. phase-lag data which based on the two layered model and the thermal conductivity and the thermal diffusivity of the thin film by the inverse problem analysis.

4. RESULTS AND DISCUSSION

4.1. Measurement of a Bi_2Te_3 Bulk Sample

In order to check the reliability of the present technique, we firstly measured an N-type sintered Bi_2Te_3 bulk sample (700 μm thickness), employed as the target material of thin films. An acrylic resin plate was employed as a backing substance. Fig. 4 shows the frequency dependence of phase-lag for the Bi_2Te_3 bulk sample. The measurements have been performed three times and the reproducibility of phase lag was

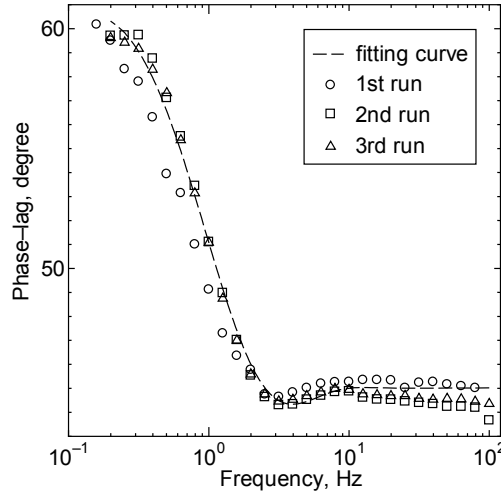

Fig. 4 Frequency vs. phase-lag data of Bi_2Te_3 bulk sample.

within $\pm 2^\circ$. We can obtain the thermal conductivity and the thermal diffusivity of the sample by solving the inverse problem analysis with the frequency vs. phase-lag data and drawing a fitting curve. Consequently, the thermal conductivity and the thermal diffusivity of the Bi_2Te_3 bulk sample were evaluated 1.7W/m/K and $1.4\text{ mm}^2/\text{s}$, respectively. The reproducibility of the values was within $\pm 10\%$. This measurement result of the thermal conductivity agreed well with the corresponding bulk value of the cited reference [6, 8].

4.2. Application to Measurement of the Submicron Thin Films

The developed apparatus was applied to evaluate the thermal conductivity of Bi_2Te_3 thin films. All the films were made by RF magnetron sputtering on Al_2O_3 substrates. The characteristic features of the Bi_2Te_3 thin films are listed in Table I. The Bi_2Te_3 crystals possess hexagonal structure as shown in Fig. 5, it is composed of atomic layers stacked along the c axis. The orientation of the films was investigated

Table I Characteristic features of the Bi₂Te₃ thin films.

Sample No.	Orientation	Substrate	Thickness [μm]
1	<i>c</i> axis	Al ₂ O ₃ (<i>c</i> plane)	1.1
2			1.8
3	dominant <i>c</i> axis		0.8
4			1
5	poly crystal		1.1
6			Al ₂ O ₃ (<i>a</i> plane)

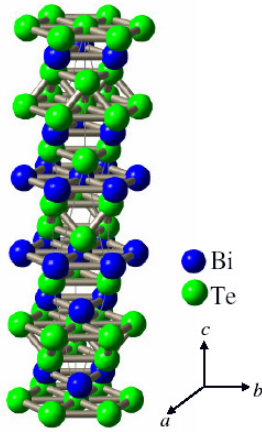

Fig. 5 Crystal structure of Bi₂Te₃.

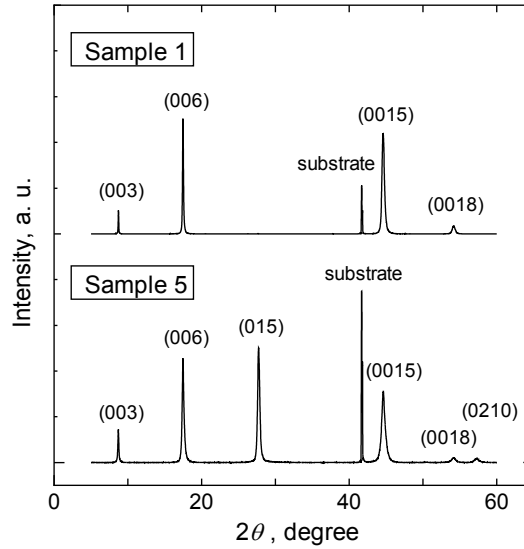

Fig. 6 X-ray diffraction patterns of sample 1 (*c* axis oriented) and sample 5 (poly crystal).

by X-ray diffraction and scanning electron microscopy. Fig. 6 shows the X-ray diffraction patterns of sample 1 and sample 5. The intense line of sample 1 indicates the (00*n*) plane which means the film oriented parallel to *c* axis. In contrast, the intense line of sample 5 indicates the (015) plane which means the film reveals poly crystalline nature. From these X-ray diffraction results, the orientation of all the films determined as *c* axis oriented, dominant *c* axis oriented or poly crystal. Fig. 7 shows the frequency dependence of phase-lag for sample 3 with 0.8 μm thickness and the fitting curve which was drawn by solving the inverse problem analysis. The measured

frequency vs. phase-lag data had some inflection points and the fitting curve was similar to the result. Fig. 8 shows the thermal conductivities of the films obtained by the inverse problem analysis.

We see from Fig. 8 that the thermal conductivities of all the films reduced in comparison with the corresponding Bi_2Te_3 bulk value. And the lowest thermal conductivity of the film indicates half as much as the corresponding Bi_2Te_3 bulk value. Moreover, since the thermal conductivity of poly crystalline film is lower than that of the highly crystalline film, it is obvious that the thermal conductivity of the film

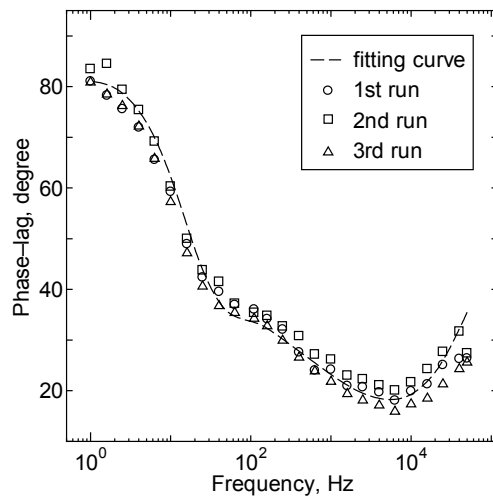

Fig. 7 Frequency vs. phase-lag data for the Bi_2Te_3 thin film Sample 3.

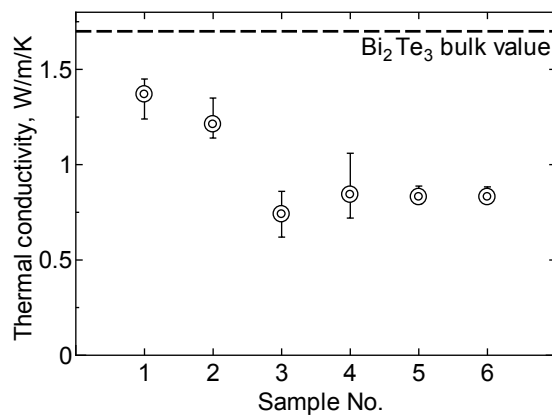

Fig. 8 The thermal conductivity of the Bi_2Te_3 thin films.

strongly depends on its own orientation.

It becomes clear to reduce the thermal conductivity of thinned Bi_2Te_3 material by the present measurements. Additionally, since the relationship between the thermal conductivity and the orientation of the film was obtained from the measurement results, we will be able to evaluate the orientation through the measurement of the thermal conductivity of a film.

The present study leads to the conclusion that the photothermal radiometry is effective measurement technique to evaluate the thermal conductivity of thin films and to design the desirable thermoelectric thin films.

ACKNOWLEDGMENTS

The work described in this paper has been supported in part by a Grant for Practical Application of University R&D Results under the Matching Fund Method from New Energy and Industrial Technology Development Organization, and by a Grant-in-Aid for Scientific Research (No.15656060). Prof. Y Yoshida of Nagoya University, K Sudo and N Nakazato of Hitachi Ltd. are gratefully acknowledged for the thin film preparation and valuable discussions. The authors thank M Nagashima who helped during the initial phases of measurement system design.

REFERENCES

- [1] G Min and D M Rowe, *Solid-State Electronics*, **43**, 923, (1999).
- [2] H Zou, D M Rowe and S G K Williams, *Thin Solid Films*, **408**, 270, (2002).
- [3] Y Nagasaka, T Sato and T Ushiku, *Meas. Sci. Technol.*, **12**, 2081, (2001).
- [4] A Rosencwaig and A Gersho, *J. Appl. Phys.*, **47**, 64, (1976).
- [5] M Akabori, Y Nagasaka and A Nagashima, *Int. J. Thermophys.*, **13**, 499, (1992).
- [6] H J Goldsmid, *Proc. Phys. Soc.*, **B69**, 203, (1956).
- [7] R Yamanaka, I Yamasaki, I Hatta, Y Mori and T Sasaki, *Netsu Bussei*, **14**, No.1, 67, (2000).
- [8] D Kusano and Y Hori, *Yokosuka Res. Lab. Rep.*, **W99025**, 1, (2000).