



# Standard Test Method for Evaluating the Resistance to Thermal Transmission of Materials by the Guarded Heat Flow Meter Technique<sup>1</sup>

This standard is issued under the fixed designation E 1530; the number immediately following the designation indicates the year of original adoption or, in the case of revision, the year of last revision. A number in parentheses indicates the year of last reapproval. A superscript epsilon ( $\epsilon$ ) indicates an editorial change since the last revision or reapproval.

## 1. Scope

1.1 This test method covers a steady-state technique for the determination of the resistance to thermal transmission (thermal resistance) of materials in thicknesses of less than 25 mm. For homogeneous opaque solid specimens of a representative thickness, thermal conductivity can be determined (see **Note 1**). This test method is useful for specimens having a thermal resistance in the range from 10 to  $400 \times 10^{-4} \text{ m}^2\cdot\text{K}/\text{W}$ , which can be obtained from materials of thermal conductivity in the approximate range from 0.1 to 30  $\text{W}/(\text{m}\cdot\text{K})$  over the approximate temperature range from 150 to 600 K. It can be used outside these ranges with reduced accuracy for thicker specimens and for thermal conductivity values up to 60  $\text{W}/(\text{m}\cdot\text{K})$ .

**NOTE 1**—A body is considered homogeneous when the property to be measured is found to be independent of specimen dimensions.

1.2 This test method is similar in concept to Test Method **C 518**, but is modified to accommodate smaller test specimens, having a higher thermal conductance. In addition, significant attention has been paid to ensure that the thermal resistance of contacting surfaces is minimized and reproducible.

1.3 The values stated in SI units are considered standard.

1.4 *This standard does not purport to address all of the safety concerns, if any, associated with its use. It is the responsibility of the user of this standard to establish appropriate safety and health practices and determine the applicability of regulatory limitations prior to use.*

## 2. Related Documents

2.1 *ASTM Standards:*<sup>2</sup>

**C 518** Test Method for Steady-State Thermal Transmission Properties by Means of the Heat Flow Meter Apparatus

<sup>1</sup> This test method is under the jurisdiction of ASTM Committee E37 on Thermal Measurements and is the direct responsibility of Subcommittee E37.05 on Thermophysical Properties.

Current edition approved Sept. 1, 2006. Published November 2006. Originally approved in 1993. Last previous edition approved in 2004 as E 1530 – 04.

<sup>2</sup> For referenced ASTM standards, visit the ASTM website, [www.astm.org](http://www.astm.org), or contact ASTM Customer service at [service@astm.org](mailto:service@astm.org). For *Annual Book of ASTM Standards* volume information, refer to the standard's Document Summary page on the ASTM website.

C 1045 Practice for Calculating Thermal Transmission Properties Under Steady-State Conditions  
E 220 Test Method for Calibration of Thermocouples By Comparison Techniques  
E 1142 Terminology Relating to Thermophysical Properties  
E 1225 Test Method for Thermal Conductivity of Solids by Means of the Guarded-Comparative-Longitudinal Heat Flow Technique  
F 104 Classification System for Nonmetallic Gasket Materials  
F 433 Practice for Evaluating Thermal Conductivity of Gasket Materials

## 3. Terminology

3.1 *Definitions of Terms Specific to This Standard:*

3.1.1 *heat flux transducer (HFT)*—a device that produces an electrical output that is a function of the heat flux, in a predefined and reproducible manner.

3.1.2 *thermal conductance (C)*—the time rate of heat flux through a unit area of a body induced by unit temperature difference between the body surfaces.

3.1.2.1 *average temperature of a surface*—the area-weighted mean temperature of that surface.

3.1.2.2 *average (mean) temperature of a specimen (disc shaped)*—the mean value of the upper and lower face temperatures.

3.1.3 *thermal conductivity ( $\lambda$ )*—(of a solid material)—the time rate of heat flow, under steady conditions, through unit area, per unit temperature gradient in the direction perpendicular to the area:

3.1.3.1 *apparent thermal conductivity*—When other modes of heat transfer through a material are present in addition to conduction, the results of the measurements performed in accordance with this test method will represent the apparent or effective thermal conductivity for the material tested.

3.1.4 *thermal resistance (R)*—the reciprocal of thermal conductance.

3.2 *Symbols:*

3.2.1  $\lambda$ —thermal conductivity,  $\text{W}/(\text{m}\cdot\text{K})$  or  $\text{Btu}\cdot\text{in.}/(\text{h}\cdot\text{ft}^2\cdot^\circ\text{F})$ .

3.2.2  $C$ —thermal conductance,  $\text{W}/(\text{m}^2\cdot\text{K})$  or  $\text{Btu}/(\text{h}\cdot\text{ft}^2\cdot^\circ\text{F})$ .

- 3.2.3  $R$ —thermal resistance,  $m^2 \cdot K/W$  or  $h \cdot ft^2 \cdot ^\circ F/Btu$ .
- 3.2.4  $\Delta x$ —specimen thickness, mm or in.
- 3.2.5  $A$ —specimen cross-sectional area,  $m^2$  or  $ft^2$ .
- 3.2.6  $Q$ —heat flow, W or Btu/h.
- 3.2.7  $\phi$ —heat flux transducer output, mV.
- 3.2.8  $N$ —heat flux transducer calibration constant,  $W/(m^2 \cdot mV)$  or  $Btu/(h \cdot ft^2 \cdot mV)$ .
- 3.2.9  $N\phi$ —heat flux,  $W/m^2$  or  $Btu/h \cdot ft^2$ .
- 3.2.10  $\Delta T$ —temperature difference,  $^\circ C$  or  $^\circ F$ .
- 3.2.11  $T_g$ —temperature of guard heater,  $^\circ C$  or  $^\circ F$ .
- 3.2.12  $T_u$ —temperature of upper heater,  $^\circ C$  or  $^\circ F$ .
- 3.2.13  $T_l$ —temperature of lower heater,  $^\circ C$  or  $^\circ F$ .
- 3.2.14  $T_1$ —temperature of one surface of the specimen,  $^\circ C$  or  $^\circ F$ .
- 3.2.15  $T_2$ —temperature of the other surface of the specimen,  $^\circ C$  or  $^\circ F$ .
- 3.2.16  $T_m$ —mean temperature of the specimen,  $^\circ C$  or  $^\circ F$ .
- 3.2.17  $s$ —unknown specimen.
- 3.2.18  $r$ —known calibration or reference specimen.
- 3.2.19  $o$ —contacts.

**4. Summary of Test Method**

4.1 A specimen and a heat flux transducer (HFT) are sandwiched between two flat plates controlled at different temperatures, to produce a heat flow through the test stack. A reproducible load is applied to the test stack by pneumatic or other means, to ensure that there is a reproducible contact resistance between the specimen and plate surfaces. A guard surrounds the test stack and is maintained at a uniform mean temperature of the two plates, in order to minimize lateral heat flow to and from the stack. At steady state, the difference in temperature between the surfaces contacting the specimen is

measured with temperature sensors embedded in the surfaces, together with the electrical output of the HFT. This output (voltage) is proportional to the heat flow through the specimen, the HFT and the interfaces between the specimen and the apparatus. The proportionality is obtained through prior calibration of the system with specimens of known thermal resistance measured under the same conditions, such that contact resistance at the surfaces is made reproducible.

**5. Significance and Use**

5.1 This test method is designed to measure and compare thermal properties of materials under controlled conditions and their ability to maintain required thermal conductance levels.

**6. Apparatus**

6.1 A schematic rendering of a typical apparatus is shown in Fig. 1. The relative position of the HFT to sample is not important (it may be on the hot or cold side) as the test method is based on maintaining axial heat flow with minimal radial heat losses or gains. It is also up to the designer whether to choose heat flow upward or downward or horizontally, although downward heat flow in a vertical stack is the most common one.

6.2 *Key Components of a Typical Device (The numbers 1 to 22 in parentheses refer to Fig. 1):*

6.2.1 The compressive force for the stack is to be provided by either a regulated pneumatic or hydraulic cylinder (1), dead weights or a spring loaded mechanism. In either case, means must be provided to ensure that the loading can be varied and set to certain values reproducibly.

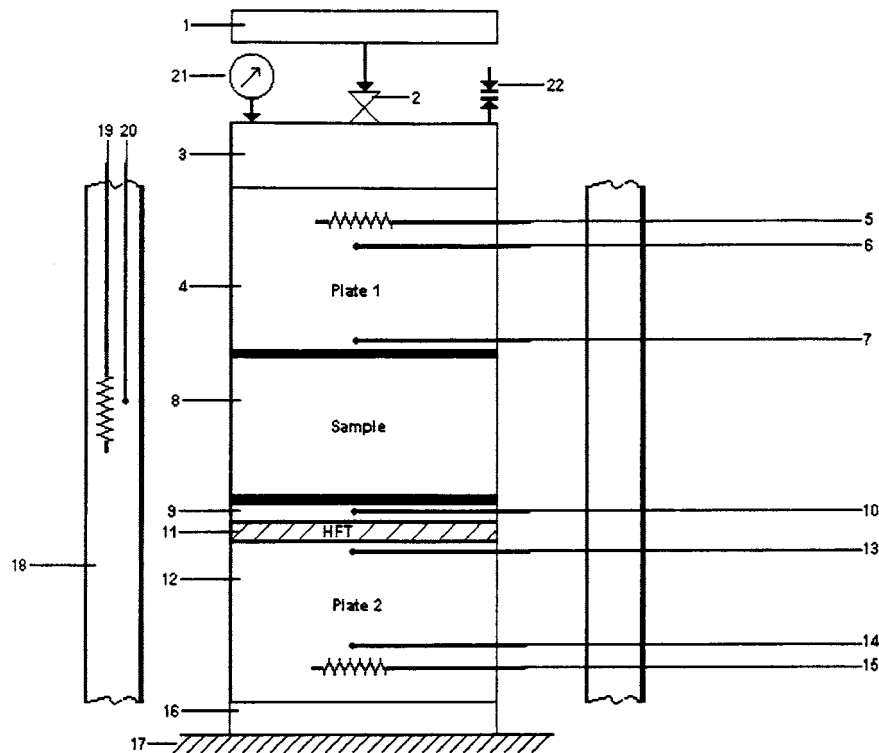

FIG. 1 Key Components of a Typical Device

6.2.2 The loading force must be transmitted to the stack through a gimball joint (2) that allows up to 5° swivel in the plane perpendicular to the axis of the stack.

6.2.3 Suitable insulator plate (3) separates the gimball joint from the top plate (4).

6.2.4 The top plate (assumed to be the hot plate for the purposes of this description) is equipped with a heater (5) and control thermocouple (6) adjacent to the heater, to maintain a certain desired temperature. (Other means of producing and maintaining temperature may also be used as long as the requirements in 6.3 are met.) The construction of the top plate is such as to ensure uniform heat distribution across its face contacting the sample (8). Attached to this face (or embedded in close proximity to it) in a fashion that does not interfere with the sample/plate interface, is a temperature sensor (7) (typically a thermocouple, resistance thermometer, or a thermistor) that defines the temperature of the interface on the plate side.

6.2.5 The sample (8) is in direct contact with the top plate on one side and an intermediate plate (9) on the other side.

6.2.6 The intermediate plate (9) is an optional item. Its purpose is to provide a highly conductive environment to the second temperature sensor (10), to obtain an average temperature of the surface. If the temperature sensor (10) is embedded into the face of the HFT, or other means are provided to define the temperature of the surface facing the sample, the use of the intermediate plate is not mandatory.

6.2.7 The heat flux transducer (HFT) is a device that will generate an electrical signal in proportion to the heat flux across it. The level of output required (sensitivity) greatly depends on the rest of the instrumentation used to read it. The overall performance of the HFT and its readout instrumentation shall be such as to meet the requirements in Section 13.

6.2.8 The lower plate (12) is constructed similarly to the upper plate (4), except it is positioned as a mirror image.

6.2.9 An insulator plate (16) separates the lower plate (12) from the heat sink (17). In case of using circulating fluid in place of a heater/thermocouple arrangement in the upper or lower plates, or both, the heat sink may or may not be present.

6.2.10 The entire stack is surrounded by a guard whose cross section is not too much different from the stack's (18) equipped with a heater and/or cooling coils (19) and a control thermocouple, resistance thermometer or thermistor (20) to maintain it at the mean temperature between the upper and lower plates. A small, generally unfilled, gap separates the guard from the stack. For instruments limited to operate in the ambient region, no guard is required but a draft shield is recommended in place of it.

NOTE 2—It is permissible to use thin layers of high-conductivity grease or elastomeric material on the two surfaces of the sample to reduce the thermal resistance of the interface and promote uniform thermal contact across the interface area.

NOTE 3—The cross-sectional area and the shape of the sample may be any, however, most commonly circular and rectangular cross sections are used. Minimum size is dictated by the magnitude of the disturbance caused by thermal sensors in relation to the overall flux distribution. The most common sizes are 25 mm round or square to 50 mm round.

6.2.11 The instrument is preferably equipped with suitable means (21) to measure the thickness of the sample, in situ, in

addition to provisions (22) to limit compression when testing elastomeric or other compressible materials.

NOTE 4—This requirement is also mandatory for testing materials that soften while heated.

### 6.3 Requirements:

6.3.1 Temperature control of upper and lower plate is to be  $\pm 0.1$  °C (0.18 °F) or better.

6.3.2 Reproducible load of 0.28 MPa (40 psi) has been found to be satisfactory for solid samples. Minimum load shall not be below 0.07 MPa (10 psi).

6.3.3 Temperature sensors are usually fine gage or small-diameter sheath thermocouples, however, ultraminiature resistance thermometers and linear thermistors may also be used.

6.3.4 Operating range of a device using a mean temperature guard shall be limited to from –100 to 300 °C, when using thermocouples as temperature sensors, and from –180 to 300 °C when platinum resistance thermometers are used. Thermistors are normally present on more restricted allowable temperature range of use.

## 7. Sampling and Conditioning

7.1 Cut representative test specimens from larger pieces of the sample material or body.

7.2 Condition the cut specimens in accordance with the requirements of the appropriate material specifications, if any.

## 8. Test Specimen

8.1 The specimen to be tested should be representative for the sample material. The recommended specimen configuration is a  $50.8 \pm 0.25$  mm ( $2 \pm 0.010$  in.) diameter disk, having smooth flat and parallel faces,  $\pm 0.025$  mm ( $\pm 0.001$  in.), such that a uniform thickness within 0.025 mm ( $\pm 0.001$  in.) is attained in the range from 0.5 to 25.4 mm (0.020 to 1.0 in.) For testing specimens with thicknesses below 0.5 mm, a special technique, described in Annex A1, has to be used. Other frequently favored sizes are 25.4 mm (1.00 in.) round or square cross section.

## 9. Calibration

9.1 Select the mean temperature and load conditions required. Adjust the upper heater temperature ( $T_u$ ) and lower heater temperature ( $T_l$ ) such that the temperature difference at the required mean temperature is no less than 30 to 35 °C and the specimen  $\Delta T$  is not less than 3 °C. Adjust the guard heater temperature ( $T_g$ ) such that it is at approximately the average of  $T_u$  and  $T_l$ .

9.2 Select at least three calibration specimens having thermal resistance values that bracket the range expected for the test specimens at the temperature conditions required.

9.3 Table 1 contains a list of several available materials commonly used for calibration together with corresponding thermal resistance ( $R_s$ ) values for a given thickness. This information is provided to assist the user in selecting optimum specimen thickness for testing a material and in deciding which calibration specimens to use.

9.4 The range of thermal conductivity for which this test method is most suitable is such that the optimum thermal resistance range is from  $10 \times 10^{-4}$  to  $400 \times 10^{-4}$  m<sup>2</sup>·K/W. The

**TABLE 1 Typical Thermal Resistance Values of Specimens of Different Materials**

Material	Approximate Thermal Conductivity W/(m·K) at 30°C	Thickness, mm	Approximate Thermal Resistance, 10 <sup>-4</sup> m <sup>2</sup> ·K/W at 30°C
Vespel <sup>3</sup> Polyimide	0.4	20	500
Vespel <sup>3</sup> Polyimide	0.4	10	250
Vespel <sup>3</sup> Polyimide	0.4	1	25
Polyethylene	0.2	1	50
Polyethylene	0.2	0.5	25
Polyethylene	0.2	0.1	5
Pyroceram 9606 <sup>4</sup>	4	20	50
Pyroceram 9606 <sup>4</sup>	4	10	25
Pyrex 7740 <sup>4</sup> Glass	1	20	200
Pyrex 7740 <sup>4</sup> Glass	1	10	100
Pyrex 7740 <sup>4</sup> Glass	1	1	10
304 Stainless Steel	14	20	14
304 Stainless Steel	14	10	7

most commonly used calibration materials are the Pyrex<sup>™</sup> 7740<sup>3</sup> and Pyroceram<sup>™</sup> 9606<sup>3</sup>, Vespel<sup>™</sup> (polyimide) and stainless steel all having well-established thermal conductivity behaviors with temperature.<sup>4</sup>

9.5 **Table 2** and **Table 3** are listing thermal conductivity values for selected reference materials, with the appropriate bibliographic references appearing in bold characters. The temperature range listed for each reference material corresponds to the temperature range mentioned in each particular cited work, and in some cases exceeds the applicable temperature range for this test method. The information was, however,

<sup>3</sup> Vespel is a product and trademark of DuPont, Wilmington, DE.

<sup>4</sup> Pyrex 7740 and Pyroceram 9606 are products and trademarks of Corning Glass Co.

considered useful for the general user, and for that reason it was listed for the entire temperature range applicable to each reference material.

## 10. Procedure

10.1 Measure the thickness of the calibration specimen to 25 μm using a suitable caliper or gauge stand.

10.2 Coat both surfaces of a calibration specimen with a very thin layer of a compatible heat transfer compound or place a thin layer of elastomeric heat-transfer medium on it to help minimize the thermal resistance at the interfaces of adjacent contacting surfaces.

10.3 Release the compressive load on the specimen stack, open the test chamber, and insert the calibration specimen. Care must be taken to ensure that all surfaces are free of any foreign matter.

10.4 Close the test chamber and clamp the calibration specimen in position between the plates at the recommended compressive load of 0.28 MPa.

10.5 Wait for thermal equilibrium to be attained. This should be seen when all the temperatures measured do not drift more than 0.1°C in 1 min. Read and record all temperatures and the output of the heat flux transducer.

NOTE 5—The time to attain thermal equilibrium is dependent upon the thickness of the specimen and its thermal properties. Experience shows that approximately 1 h is needed for thermal equilibrium to be attained, when operating the instrument within its optimum operating range.

10.6 Repeat 10.1-10.5 with the rest of the calibration specimens used, having different thermal resistance values covering the expected range for the test specimen.

10.7 *Thermal Conductivity of an Unknown Specimen:*

**TABLE 2 Thermal Conductivity Values of Selected Reference Materials**

Temperature (°C)	Thermal Conductivity (W/(m <sup>1</sup> ·K <sup>1</sup> ))		
	Vespel <sup>A</sup>	Pyrex 7740 <sup>B</sup>	Pyroceram 9696 <sup>C</sup>
-50	...	1.010	...
0	...	1.104	...
25	0.377	1.177	4.03
100	0.391	1.236	3.65
200	0.413	1.330	3.40
300	0.436	1.447 <sup>D</sup>	3.24
400	...	...	3.14
500	...	...	3.05
600	...	...	2.98
700	...	...	2.91
800	...	...	2.84
900	...	...	2.77
1000	...	...	2.71

<sup>A</sup>R. A. Jacobs-Fedore and D. E. Stroe, *Thermophysical Properties of Vespel<sup>™</sup> SP1*, in Thermal Conductivity 27 / Thermal Expansion 15, DEStech Publications, Inc., 2004, pp 231-238.

<sup>B</sup>R. P. Tye and D. R. Salmon, *Thermal Conductivity Certified Reference Materials: Pyrex 7740 and Polymethylmethacrylate*, National Physical Laboratory report, 2004, Teddington, United Kingdom.

<sup>C</sup>D. E. Stroe, M. A. Thermitus and R. A. Jacobs-Fedore, *Thermophysical Properties of Pyroceram<sup>™</sup> 9606*, in Thermal Conductivity 27 / Thermal Expansion 15, DEStech Publications, Inc., 2004, pp 382-390.

<sup>D</sup>R. W. Powell, C. Y. Ho and P. E. Liley, *Thermal Conductivity of Selected Materials*, Special Publication NSRDS-NBS8, National Bureau of Standards, Washington DC.

**TABLE 3 Thermal Conductivity Values of Selected Reference Materials<sup>A,B</sup>**

Temperature (°C)	Thermal Conductivity (W/(m <sup>1</sup> ·K <sup>1</sup> ))			
	310 Stainless Steel	430 Stainless Steel	Inconel 600	Nimonic 75
50	13.2	20.9	13.3	12.8
100	14.1	21.6	14.2	13.7
200	15.9	22.8	15.9	15.4
300	17.7	23.8	17.8	17.2
400	19.5	24.5	19.7	19.1
500	21.2	24.9	21.7	21.1
600	23.0	25.1	23.7	23.1
700	24.8	25.9	25.8	25.2
750	25.7	26.4	26.9	26.2

<sup>A</sup>J. Clark and R. Tye, *Thermophysical Properties Reference Data for Some Key Engineering Alloys*, High Temperatures – High Pressures, 2003/2004, volume 35/36, pp. 1-14. .

<sup>B</sup>R.P. Tye and D.R. Salmon, "Development of New Thermal Conductivity Reference Materials: A Summary of Recent Contributions by National Physical Laboratory". in Thermal Conductivity 27/ Thermal Expansion 15, DEStech Publications, Inc., 2004, pp 372–381.

10.7.1 Tests shall only be conducted at a temperature in a range and under applied load conditions for which valid calibration data exists.

10.7.1.1 When automatic control of temperature of the heaters is involved, the controller settings should be checked to ensure that they are the same as those used for the calibration.

10.7.2 Measure the thickness of the specimen to 25 μm using a suitable caliper or gauge stand.

10.7.3 Apply a thin layer of heat transfer compound or place a thin layer of elastomeric heat transfer medium on the surfaces of the test specimen. This may be unnecessary for specimens of flexible materials.

NOTE 6—Care must be taken to ensure that any material applied to the surfaces of the specimen does not change its thermal properties, by soaking into it.

10.7.4 Repeat 10.3-10.5 using the test specimen. For compressible materials, it is mandatory to measure in situ the sample thickness under load to within ± 100 μm, and, if necessary, to limit further compression by suitable mechanical stop.

10.8 *Thermal Conductivity of Thin Specimens*—For specimens less than approximately 0.5 mm (0.020 in.) in thickness (and for those whose thickness is less than 1 mm (0.040 in.) and thermal conductivity is greater than 0.5 W/(m·K)), a special stacking technique can be used. This is described in detail in Annex A1.

NOTE 7—Experience has indicated that for reliable measurements on a single specimen, the minimum thickness (mm) is given by  $\Delta x \geq 3\lambda$ , with  $\lambda$  expressed in W/(m·K).

10.9 *Automated Systems*: Computerized or otherwise automated systems may require different operating steps, and may or may not provide intermediate readings described in 10.5. For these devices, follow the operating and calibrating procedures prescribed by the manufacturer.

NOTE 8—For an automated system to meet the requirements of this test method, the calibration test method, and the calculation built into it shall

at minimum include the steps or principles set forth in 10.1-10.8, and all applicable guidelines given in Sections 6, 9, 12, and 13.

## 11. Calculation

11.1 At equilibrium, the Fourier heat-flow equation applied to the system becomes as follows:

$$R_s = \frac{N(T_1 - T_2)}{Q} - R_o \quad (1)$$

and:

$$C_s = \frac{1}{R_s} \quad (2)$$

For homogeneous materials:

$$R_s = \frac{\Delta x}{\lambda} \quad (3)$$

11.1.1 In Eq 1,  $N$  and  $R_o$  are temperature— and load-dependent parameters obtained by calibration at each particular set of conditions. Once obtained, they should remain fixed for the particular settings used to attain the conditions.

NOTE 9—Since  $N$  is also determined by the particular HFT utilized, the calibration should be checked occasionally to ensure that continuous heating/cycling does not affect the HFT.

NOTE 10—The parameter  $R_o$  depends on the parallelism of the two surface plates and should be reproducible unless the test section is altered mechanically in any way. If this occurs, recalibration is necessary.

11.2 There are three methods of data analysis to determine  $R_s$ ,  $C_s$  and  $\lambda$ . In each case, utilize relevant input parameters determined to the stated precision levels and use all available decimal places through the calculation stages to the final result. Calculate the thermal resistance  $R_s$  to the nearest whole number in practical units of  $10^{-4}$  m<sup>2</sup>·K/W, and derive values of thermal conductivity to the second significant figure level of precision.

11.2.1 *Graphical Method*—At each set of conditions, Eq 1 is represented by a straight line on a graph of  $R_s$  versus  $(T_1 - T_2)/Q$ . Plot the test result of several calibration specimens on the graph, and draw a best-fit straight line through the data

points as illustrated in Fig. 2. When measuring the thermal conductivity of a test specimen, obtain  $R_s$  by drawing a vertical line at the appropriate value of  $(T_1 - T_2)/Q$  to intersect the calibration line. Obtain values of  $C_s$  and  $\lambda_s$  from Eq 2 and 3.

11.2.2 *Analytical Method*—At each set of conditions, solve Eq 1 mathematically for  $N$  and  $R_o$  after measuring a pair of reference specimens to yield two sets of data for  $R_s$  and  $(T_1 - T_2)/Q$ . Eq 1 can be used subsequently to determine  $R_s$  of the test specimen following measurement of  $T_1$ ,  $T_2$ , and  $Q$  providing the calculated  $R_s$  falls within the calibration range corresponding to the particular pair of reference specimens in accordance with 9.2. By calibrating with additional reference specimens of different thermal resistances, several linear equations can be generated, each covering a part of the overall range.

### 11.2.3 Computer-Aided Analysis:

11.2.3.1 At each set of conditions, solve Eq 1 mathematically for  $N$  and  $R_o$ , using a linear regression analysis of the results for several sets of data for  $R_s$  and  $(T_1 - T_2)/Q$  produced as a result of testing several calibration specimens. A similar series of tests carried out at the different temperatures provides new values of  $N$  and  $R_o$ .

11.2.3.2 Determine a polynomial relationship between  $N$  and temperature, and between  $R_o$  and temperature, so that Eq 1 becomes:

$$R_s = f_1(T) \cdot \frac{T_1 - T_2}{Q} - f_2(T) \quad (4)$$

where:

$f_1(T)$  = temperature dependent value of  $N$ ,  
 $f_2(T)$  = temperature dependent value of  $R_o$ , and  
 $T$  = test temperature.

11.2.3.3 The values of  $R_s$  and  $\lambda$  of the test specimen are calculated automatically, once  $T_1$ ,  $T_2$  and  $Q$  have been measured. Results are accurate provided that the test temperatures fall within the limits used during calibration, and that  $R_s$  does not fall outside the calibration range obtained with the reference specimens.

## 12. Report

12.1 Report the following information:

12.1.1 Complete identification and description of material and specimen including any conditioning procedure;

12.1.2 Details of reference specimen materials used for calibration;

12.1.3 Details of temperatures of appropriate surfaces, guard and ambient, °C (°F);

12.1.4 Applied load, Pa (psi);

12.1.5 Specimen thickness, mm (in.);

12.1.6 Mean temperature, °C (°F);

12.1.7 Measured thermal resistance to the nearest whole number in practical units,  $10^{-4} \text{ m}^2 \cdot \text{K}/\text{W}$  ( $\text{h} \cdot \text{ft}^2 \cdot ^\circ\text{F}/\text{Btu}$ ) and derived thermal conductivity to the second significant figure in  $\text{W}/(\text{m} \cdot \text{K})$  ( $\text{Btu} \cdot \text{in.}/(\text{h} \cdot \text{ft}^2 \cdot ^\circ\text{F})$ ). Include details of the calculation method used (for manual instruments, omit for automated systems);

12.1.8 The sample's mean temperature and the direction and orientation of thermal transmission through the sample, since some bodies are not isotropic with respect to thermal conductivity;

12.1.9 Designation of model/make in case a commercial device is used.

## 13. Precision and Bias

13.1 *Precision*—An interlaboratory study, summarized in Annex A3, involving four organizations and three materials having different thermal conductivity values in the applicable range of the test method has shown that a precision of  $\pm 5\%$  can be attained on a single specimen. If the specimen is in the form of two pieces clamped together, the precision is  $\pm 7\%$ .

13.2 *Bias*—Based on comparison with measurements made by an absolute method, there is no significant bias when measurements are made on single specimens.

## 14. Keywords

14.1 heat flow meter; heat flux transducer; thermal conductance; thermal conductivity; thermal resistance; thin specimen

Thermal Resistance vs.  $(T1-T2)/Q$

Figure 2

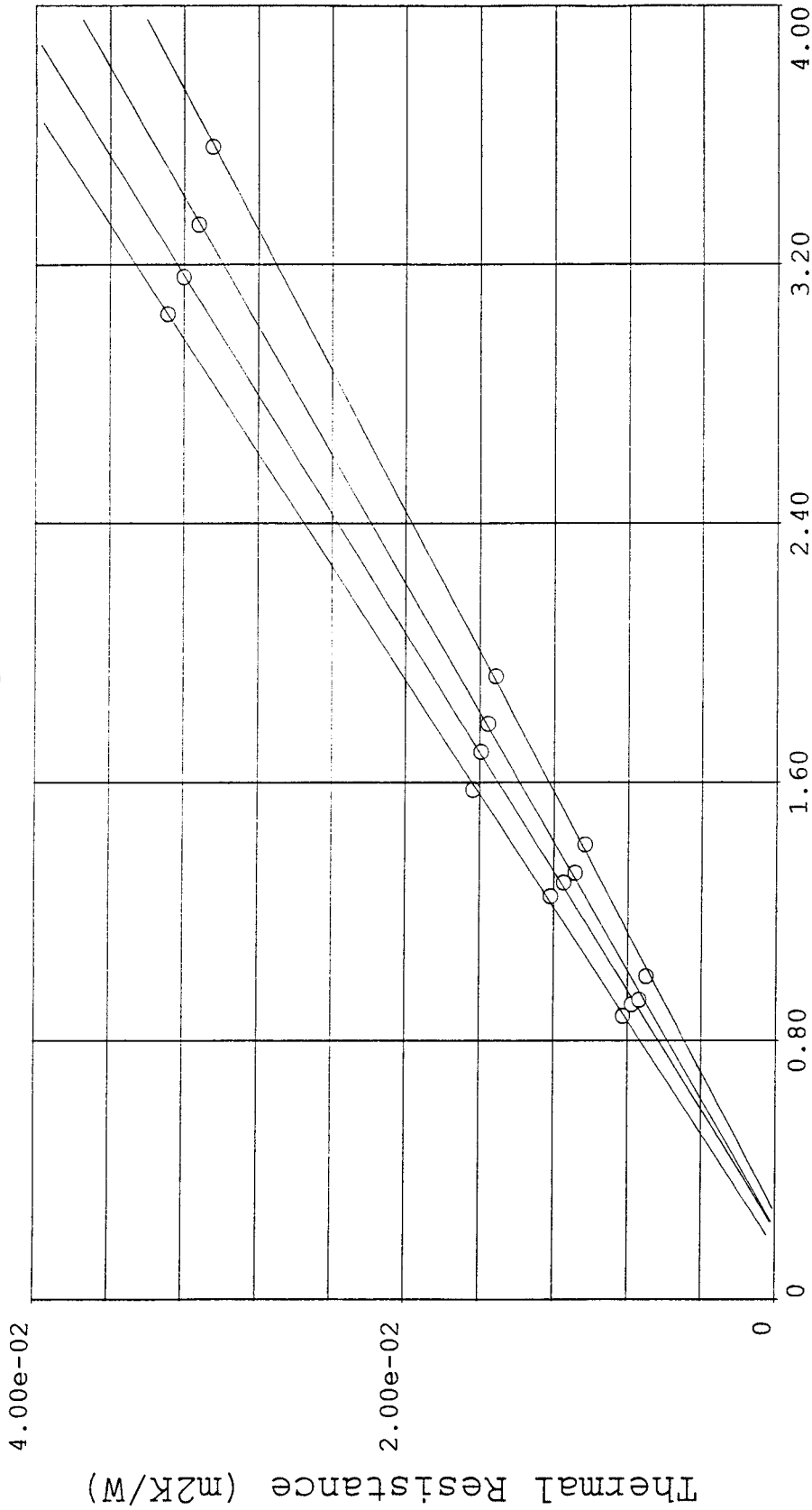

$(T1-T2)/Q$

FIG. 2 Thermal Resistance Versus  $(T1-T2)/Q$

## ANNEXES

### (Mandatory Information)

#### A1. TESTING OF THIN SPECIMENS LESS THAN 0.5 mm IN THICKNESS

A1.1 This technique involves evaluation of the thermal resistance of thin specimens by testing them stacked, providing that the thermal resistance of the interface between the layers is negligibly small. This assumption is valid for most flexible materials, such as: plastics, rubber, papers, and so forth, having relatively low thermal conductivity values.

A1.2 Several specimens have to be cut from the material to be tested, all of them having the same cross section with the instrument's stack.

A1.3 One or two stacked specimens have to be tested first, to evaluate if the thermal resistance falls within the calibration range of the instrument.

NOTE A1.1—No thermal compound or oil should be used between the layers of specimens or between the specimens and the instrument. Since the thermal resistance of these interfaces will be considered negligible, the number of specimens stacked should be reduced to the minimum necessary. Testing up to five or six layers is usually sufficient.

A1.3.1 If the thermal resistance values of one or two specimens tested together fall within the instrument's calibration range, the testing process should continue by testing three, four, and five layers of materials, stacked. It is recommended to have at least four different numbers of layers of material tested.

NOTE A1.2—If the specimens show a low thermal resistance value when tested in one or two layers, but they have the tendency to stick to each other under compression, minimizing the thermal resistance between them, higher numbers of layers can be tested (for example, four, five, six, seven, and so forth).

A1.3.2 If the thermal resistance values of one or two specimens tested together are considerably lower than the minimum value of the instrument's calibration range, the specimens have to be stacked on a reference material and tested together with it. It is recommended that one of the reference materials used for the instrument's calibration should be considered for this particular application.

A1.4 Upon completion of the tests, determine the thermal resistance ( $R_s$ ) of each set of specimens using an appropriate data reduction method, in accordance with 11. Plot the thermal resistance ( $R_s$ ) versus the specimen thickness (total thickness of the stacked specimens, not including the thickness of the reference material, if used). The slope of the line obtained is the inverse of the thermal conductivity of the material tested.

A1.5 Due to the compressibility of the samples, in situ thickness measurement and compression limiting stop capabilities are mandatory requirements for the instrument used.

#### A2. TESTING OF LIQUIDS AND PASTES

A2.1 When the materials to be tested are liquids or pastes, special holders or cells have to be used for containing the specimen inside the test chamber. It is important that the cells are manufactured in such a way that the thickness of the specimen is well defined and constant during the test. This is particularly important in cases when the measurements are performed at elevated temperatures and the material's thermal expansion during the test becomes unavoidable. The cells should have provisions for eliminating the excess material as the specimen expands, and maintaining the specimen's thickness still constant.

A2.2 The instrument has to be specially calibrated with reference materials placed inside the cells, before performing the tests.

A2.3 Special care has to be taken to avoid convection currents occurring in the liquid specimens. For this reason, liquids should be test using the thinnest possible specimen that

would allow performing the measurement within the instruments's operating range.

A2.4 Liquids should not be tested at temperatures that generate high vapor pressures, since this would disturb the one-dimensional heat flow theory on which this test method is based.

A2.5 A frequent application in which cells are used for containing the specimen, is performing tests on materials that would undergo a melting process during the test. The specimen is initially in solid state, and becomes liquid as the test temperature increases. This particular application needs a cell that would fit the solid specimen perfectly and would hold the sample, as it becomes liquid, maintaining its constant thickness all throughout the test and allowing the excess of liquid to be eliminated from the cell, without interfering with the instrument.



### A3. SUMMARY OF INFORMATION FOR PRECISION AND BIAS STATEMENT

A3.1 An interlaboratory comparison was carried out on three different molding compounds by four organizations under the auspices of Semiconductor Equipment and Materials Institute, Inc. The four organizations involved were Fiberite Corp.; Holometrix, Inc.; Hysol Division of Dexter Corp.; and Plaskon Electronic Materials, Inc.

A3.2 The four materials were described as low, L; medium M; and high, H, thermal-conductivity molding compounds, respectively. Measurements using the guarded heat flow meter

method were carried out at approximately 40°C on 12-mm thick specimens, 50-mm diameter disks each. For the L and M materials, measurements were also carried out on two 6-mm thick specimens stacked together. Separate measurements were made by one organization on other larger specimens cut from the same samples using an absolute method of measurement of thermal conductivity.

A3.3 The results obtained are summarized in **Table A3.1**

**TABLE A3.1 Thermal Conductivity, W/(m·K) of Four Molding Compounds**

Organization	12 mm thick			2 samples, 6 mm thick each			Absolute Method		
	L	M	H	L	M	H	L	M	H
A	0.605	1.24	1.83	0.590	1.14	—	—	—	—
B	0.594	1.24	2.00	0.570	1.19	—	0.60	1.27	1.97
C	0.624	1.31	1.92	0.611	1.22	—	—	—	—
D	0.592	1.25	1.94	0.577	1.20	—	—	—	—

*ASTM International takes no position respecting the validity of any patent rights asserted in connection with any item mentioned in this standard. Users of this standard are expressly advised that determination of the validity of any such patent rights, and the risk of infringement of such rights, are entirely their own responsibility.*

*This standard is subject to revision at any time by the responsible technical committee and must be reviewed every five years and if not revised, either reapproved or withdrawn. Your comments are invited either for revision of this standard or for additional standards and should be addressed to ASTM International Headquarters. Your comments will receive careful consideration at a meeting of the responsible technical committee, which you may attend. If you feel that your comments have not received a fair hearing you should make your views known to the ASTM Committee on Standards, at the address shown below.*

*This standard is copyrighted by ASTM International, 100 Barr Harbor Drive, PO Box C700, West Conshohocken, PA 19428-2959, United States. Individual reprints (single or multiple copies) of this standard may be obtained by contacting ASTM at the above address or at 610-832-9585 (phone), 610-832-9555 (fax), or service@astm.org (e-mail); or through the ASTM website (www.astm.org).*