

Design Concepts for a New Guarded Hot Plate Apparatus for Use Over an Extended Temperature Range

By

Robert R. Zarr and William Healy

Heat Transfer and Alternative Energy Systems Group
Building and Fire Research Laboratory
National Institute of Standards and Technology
Gaithersburg, MD 20899-8632

And

James J. Filliben
Manufacturing Metrology Division
National Institute of Standards and Technology
Gaithersburg, MD 20899-8220

And

Daniel R. Flynn
President and Chief Scientist
MetSys Corporation
Millwood, VA 22646-0317

Reprinted from STP 1426, ASTM International Standards,
Insulation Materials, Testing and Applications, V4, 2002
ISBN 0-8031-2898-3

NOTE: This paper is a contribution of the National Institute of Standards
And Technology and is not subject to Copyright.

Daniel R. Flynn,¹ Robert R. Zarr,² Mahn Hee Hahn,³ and William M. Healy²

Design Concepts for a New Guarded Hot Plate Apparatus for Use Over an Extended Temperature Range

REFERENCE: Flynn, D. R., Zarr, R. R., Hahn, M. H., and Healy, W. M., “**Design Concepts for a New Guarded Hot Plate Apparatus for Use Over an Extended Temperature Range,**” *Insulation Materials: Testing and Applications: 4th Volume, ASTM STP 1426*, A. O. Desjarlais and R. R. Zarr, Eds., ASTM International, West Conshohocken, PA, 2002.

ABSTRACT: The National Institute of Standards and Technology is building a new guarded hot plate apparatus (GHP) for use at temperatures from 90 to 900 K, with provision to conduct tests in various gases at controlled pressures from 0.013 Pa to 0.105 MPa (≈ 1.04 atm). Important features of the design of the new NIST GHP include: enclosure of the entire apparatus in a vacuum chamber; solid metal hot plates and cold surface plates to provide highly isothermal surfaces in contact with the test specimens; an integral close-fitting edge guard to minimize the effects of edge heat losses or gains; connection guard blocks to minimize the effects of heat conduction along coolant lines, heater leads, thermometry wells, and sensor leads coming from the hot plate and the cold plates; provision of a system to provide a known clamping force between the specimens and the contacting hot and cold plate surfaces; provision of an accurate system for *in-situ* measurement of specimen thickness during a test; and the use of three long-stem standard platinum resistance thermometers to measure the average temperature of the meter plate and the two cold plates.

KEYWORDS: guarded hot plate, heat conduction, heat transfer, insulation, R-value, thermal conductivity, thermal insulation, thermal resistance

Introduction

The guarded hot plate apparatus is generally recognized as the primary absolute method for measurement of the thermal transmission properties of homogeneous insulation materials in the form of flat slabs. This test method has been standardized as ASTM Test Method for Steady-State Heat Flux Measurements and Thermal Transmission Properties by Means of the Guarded-Hot-Plate Apparatus (C 177) and ISO International Standard: Thermal Insulation – Determination of Steady-State Thermal Resistance and Related

¹President and Chief Scientist, MetSys Corporation, Millwood, VA 22646-03 17.

²Mechanical Engineer, Building and Fire Research Laboratory, National Institute of Standards and Technology, Gaithersburg, MD 20899.

³Mechanical Engineer, Manufacturing Engineering Laboratory, National Institute of Standards and Technology, Gaithersburg, MD 20899.

Thermal Insulation – Determination of Steady-State Thermal Resistance and Related Properties – Guarded-Hot-Plate Apparatus (ISO 8302), with the two test methods being very similar, but not identical. Over the temperature range to which typical building insulations are exposed, interlaboratory comparisons on well-behaved materials have shown that different guarded hot plate apparatus can produce thermal conductivity or thermal resistance values with differences of ± 2 or 3 percent. However, interlaboratory comparisons among different guarded hot plate apparatus at higher temperatures (e.g., 400 K to 1000 K), in both North America [1] and in Europe [2], have revealed variations in thermal properties ranging from ± 12 to 18%. There do not appear to have been similar interlaboratory comparisons for guarded hot plate measurements at cryogenic temperatures but larger uncertainties than near room temperature could be expected there.

The good agreement among different guarded hot plate apparatus near room temperature is believed to be in large part due to the ready availability of certified reference materials that have been measured by one or more national standards laboratories, and that can be used by various laboratories to check out their own thermal transmission measurement equipment. Very few national standards laboratories have guarded hot plate apparatus that are known to provide reliable calibration data at cryogenic temperatures or at high temperatures, so the availability of certified reference materials for use at these more extreme temperatures is quite limited. For many years, ASTM Committee C-16 on Thermal Insulation has been asking NIST to provide suitable reference materials for use over the broad temperature range of interest for various applications of industrial insulations. In addition to there being a need for reference materials for use over a broad temperature range in air, NIST perceives a need for reference materials whose thermal transmission properties are well known when the insulation is evacuated or filled with a gas of high molecular weight, such as might be the case for cryogenic insulations or the advanced insulation panels that are being developed for use in refrigerators, freezers, and refrigerated transport.

In order to have the capability of measuring thermal transmission of commercial products and candidate reference materials over a broad range of temperatures and gas pressures, NIST and MetSys Corporation (under an SBIR contract) have undertaken a project to design, analyze, fabricate, and evaluate a new 500 mm diameter guarded hot plate apparatus for the determination of steady-state thermal transmission properties of insulating and building materials at mean temperatures from 90 K to 900 K. Ultimately, the apparatus will be provided with the capability of carrying out such measurements at controlled gas pressure from 0.01 Pa to 0.105 MPa (≈ 1.04 atm), with dry air or a selected filler gas.

The present paper includes a summary of some of the perceived problems with previous designs of guarded hot plate apparatus, the performance criteria for the new guarded hot plate to be built at NIST, and the design concepts that will be used to ensure that the new apparatus will be convenient to use and that it will provide accurate thermal conductivity and thermal resistance data over a broad range of temperatures and pressures.

Background

Traditionally, most guarded hot plate apparatus have been constructed using a metal-surfaced laminated design, in which an electrical heater on a central electrically insulating plate is sandwiched between two thin electrically insulating plates which in turn are

sandwiched between two metal surface plates. While such designs can work quite well in air at temperatures in the range of, say, 240 K to 340 K, problems are often encountered at higher or lower temperatures or if it is desired to measure the thermal transmission of specimens under vacuum conditions. At higher temperatures, the meter plate may be constructed as a sandwich of a ceramic plate, with an embedded heater, between two metal plates. Laminated hot plates typically must use materials having different thermal expansion coefficients so that such plates are subject to warping at either low temperatures or high temperatures, with attendant large thermal contact resistances between the surface plates and the specimens. At low temperatures, and particularly under vacuum conditions, thermal contact resistances between the different layers can be quite large, resulting in the meter and guard heaters being considerably hotter than the surface plates, a situation that can result in poor guarding and possible temperature variations over the surface plates. Laminated designs are generally not suitable for use in vacuum since they are subject to severe outgassing and, if a good vacuum is achieved, the thermal contact between the heater plates and the metal plates is poor, particularly at lower temperatures where radiative heat transfer across the thermal contacts is low. Rather than using laminated metal-surface constructions, some high-temperature guarded hot plate designs have used ceramic plates with electrical heaters embedded in them. If the meter, guard, and auxiliary plates are made of ceramic, they typically are made rather thick in order to provide increased lateral thermal conductance; even so, the thermal conductivity of most ceramics is approximately inversely proportional to the absolute temperature so that the plate thermal conductivities become quite low at high temperatures, making it difficult to achieve isothermal plate surfaces. In addition, the electrical resistivity of ceramics drops sharply with increasing temperature so that it can be difficult to avoid electrical leakage from the heaters to the temperature sensors.

In the early 1960s, Robinson conceived the idea of building a circular guarded hot plate as solid metal plates with embedded line heat sources, one in the meter plate and one in the guard plate, rather than to distribute the heating elements over the area of each plate. In an unpublished 1964 paper [3-5], he described his concept, developed the mathematical analysis behind his proposed design, and listed some of the virtues he saw for a line-heat-source guarded hot plate, as compared to the conventional distributed-heater design:

“1. There is no danger that a surface temperature thermocouple, or more seriously perhaps, a gap thermocouple, may give an erroneous result because one of its junctions happens to be too close to a wire of one of the heater windings. Difficulties of this kind have occurred in carefully-made hot plates with distributed grid heaters, and are not easily discovered.

“2. Although it is not necessary, it appears that most metal-surfaced hot plates with distributed grid heaters are square in shape. Because of the corners, the problem of getting a good average balance of across-gap temperatures along the entire length of the guard gap is more difficult than it is for the circular design described here.

“3. The guard section of a guarded hot plate operates with practically no heat exchange laterally at the gap separating it from the metering section, but usually some heat exchange occurs at its outer edges. With a uniformly-distributed heater, this means that some radially-directed lateral temperature gradients must exist, which may significantly disturb the uniformity of guard surface temperature near the gap. With the line-source heated guard

described, the radial lateral temperature gradients near the periphery can exist, but do not disturb the temperatures of the inner part of the guard within the radius of the heater.

“4. The flatness, and thickness, of a hot plate made of a solid plate of metal operated at very nearly a uniform temperature are subject to no change except as a result of thermal expansion of the metal, which can be calculated if significant. The flatness, and thickness, of a hot plate made with laminations of electrical insulation, a distributed heater winding on a template, and relatively thin metal face plates, all held together by screws, may both be questionable at various temperatures, or after a period of use. In measurements on thin or quite conductive materials, uncertainties as to thickness or flatness of the hot plate may be important, particularly if specimen thickness is measured in the apparatus, which is desirable if the specimen changes in thickness with temperature.”

In the early 1970s, Hahn carried out a thorough mathematical analysis and developed a detailed design for a line-heat-source guarded hot plate apparatus [6]. After Robinson's death, a summary of his analysis and of Hahn's analysis and design were presented at an ASTM C-16 conference and published in 1974 [7]. In this paper, it was stated that some of the specific problems which may be associated with a distributed heater winding such as typically used include the following:

“1. Construction and repair of the heaters is somewhat complicated and difficult.

“2. The construction by lamination of different materials can lead, because of differential expansion, to warpage of the hot plate, which may result in nonuniform thermal contact with the specimens and difficulty in accurate *in situ* measurements of specimen thickness.

“3. Repeated thermal cycling of the apparatus can lead to permanent deformation of the hot plate.

“4. The need for structural integrity of the laminated design requires excessive material bridging the gap thus resulting in a high thermal conductance between the metering and bridge sections.

“5. It is difficult to locate and install thermocouples so as to determine the average surface temperatures of the metering section.

“6. It is difficult to locate and install a thermopile so as to adequately reflect the average temperature difference across the gap.

“7. The hot plate design is rather unsuitable for vacuum operation because of outgassing problems and uneven temperature distributions due to poor and nonuniform thermal contacts among the elements of the hot plate.”

In 1978, construction of a prototype line-heat-source guarded hot plate apparatus, based on Hahn's design, with a diameter of 305 mm was completed [8-10]. Hahn then led the design and construction effort that resulted in the completion, in 1980, of a 1016-mm diameter apparatus [11-14], that is still in very active use today. Recently Zarr and Hahn documented the detailed designs of both of these apparatus [15].

During the 1980s, the key design features for a line-heat-source guarded hot plate were standardized as ASTM Standard Practice for Guarded-Hot-Plate Design Using Circular Line-Heat Sources C 1043). During the mid-1990s, the scope of C 1043 was substantially extended. As part of this effort, consideration was given to the design of line-heat source guarded hot plate apparatus to be used at elevated temperatures or for measurement of the thermal transmission of specimens that have lower thermal resistances than is the case for

thick specimens of good thermal insulations at temperatures near to normal ambient. Analyses were carried out which showed that accurate thermal transmission measurements for higher conductance specimens would benefit from the use of a line-heat-source guarded hot plate apparatus with multiple circular line heat sources, rather than just one or two, in the meter plate and in the guard plate. Accordingly, in the revision of C 1043, an annex was added that provides guidance on how and where to locate the heaters in such apparatus. Since that annex was written, substantial additional analyses relative to the location of heaters in a guarded hot plate apparatus have been carried out [16].

Problems With Prior Designs

Some of the problems that have been encountered with guarded hot plates for use at cryogenic temperatures or high temperatures are summarized in Table 1. The difficulties with the design of the hot plate have been discussed above in some detail. Similar concerns apply to the design of the cold plates when it is necessary that they be equipped with heaters, rather than just coolant coils, as is the case for many GHPs for use near room temperature.

Edge Guarding

In many guarded hot plate apparatus used at moderate temperatures, the equipment is inside an environmental chamber whose temperature can be adjusted to be nearly equal to the average temperature of the test specimens. By this means, with or without the use of edge insulation, the effect of heat gains to or losses from the edge of the guard plate and the specimens can be kept acceptably small. In many high-temperature guarded hot plate apparatus, a cylindrical edge guard is used to control the temperature of the outside of the edge insulation to be close to the specimen mean temperature. Figure 1 shows the overall layout (not necessarily to scale) of a typical high-temperature guarded hot plate apparatus. The (usually cylindrical but sometimes square) "stack" is symmetrical about the mid-plane of the apparatus. All of the electrical power input to the meter plate heater ideally flows through the meter area (i.e., an area equal to the area of the meter plate plus half of the area of the guard gap between the meter plate and the guard plate) of the specimens.

The guard plate temperature is controlled by a thermopile across the guard gap so that there is, again ideally, no heat flow across the guard gap. Each auxiliary plate, which is the "cold plate" as far as the specimen is concerned, is provided with an electrical heater and is controlled to the desired cold-side temperature. The auxiliary insulation between each auxiliary plate and the corresponding coolant plate keeps the heat load to the auxiliary plate heater to a reasonable value. Each coolant plate is cooled by circulating water or some other liquid. The edge guard, which is significantly larger in inside diameter than the outer diameter of the stack, is usually controlled at a temperature close to the mean temperature of the specimens so as to minimize edge heat losses. There frequently is a cooled shroud (not shown) outside of, and coaxial with, the edge guard. The space between the stack and the edge heater, and that between the edge heater and the shroud are filled with loose-fill insulation. Permanently installed thermocouples are located in the meter plate, guard plate, auxiliary plates, and edge guard.

Table 1 - *Resign Concerns for GHPs for Use Over Extended Temperature Ranges*

Component	Concerns
Hot and Cold Plates	
<ul style="list-style-type: none"> Laminated construction with metal surface plates Ceramic plates with embedded heaters 	<p>Warping, poor thermal contact between layers, lateral temperature variations, outgassing</p> <p>Low thermal conductivity at high temperatures, electrical leakage at high temperatures</p>
Edge Guarding	
<ul style="list-style-type: none"> Guard design Fill insulation 	<p>Spatial temperature variations, shunting heat flows</p> <p>Messy, not suitable for vacuum</p>
Heaters and Sensors	
<ul style="list-style-type: none"> Connection leads 	Parasitic heat flows
Temperature Measurement	
<ul style="list-style-type: none"> Alloy thermocouples Pure element thermocouples 	<p>Calibration uncertainties</p> <p>Inadequate sensitivities at cryogenic temperatures</p>
Thickness Measurement	
<ul style="list-style-type: none"> Room temperature only In situ 	<p>Thickness may change due to variable compressive force and/or thermal expansion</p> <p>Difficult to achieve desired accuracy</p>

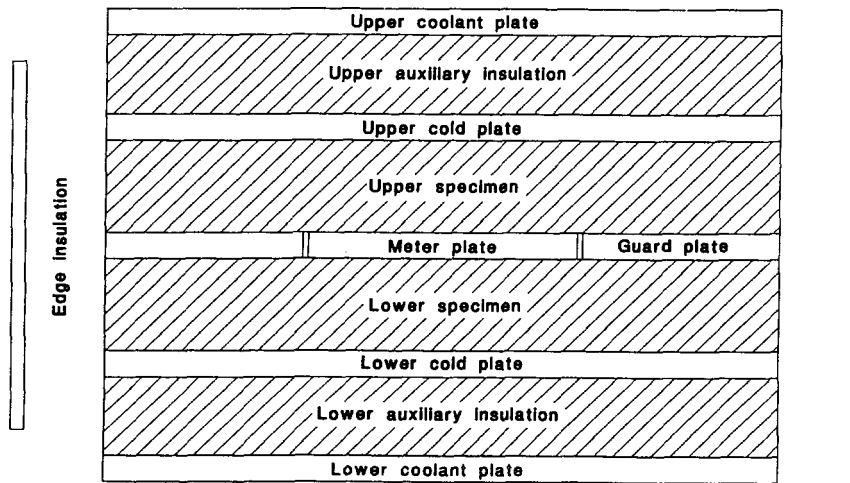

Figure 1 - *Atypical high-temperature guarded hot plate apparatus*

The type of edge guard shown in Figure 1 can lead to very serious errors. For some designs, the edge guard is not sufficiently conductive, or the heater is not properly distributed, to ensure that the edge guard is uniformly maintained at the desired average temperature. Even if the guard is isothermal, for tests at a high mean temperature, the edges of the guard plate, the two specimens, and the two auxiliary plates will be much hotter than the coolant plates, with the resultant effect that there are very large longitudinal heat flows in the insulation that fills the annulus between the stack and the edge guard. The longitudinal heat flow near the stack in this annulus must be provided by radial heat losses from the edges of the auxiliary plates, the edges of the specimens, and even, for thin specimens, from the edge of the guard plate. The analysis which was carried out shows that there can be large net heat losses from the edges of the specimen, even when the edge guard is at the mean temperature of the specimen [16].

Heaters and Sensors

As indicated in ISO 8302, it is important that heater and sensor leads be thermally tempered so that heat conduction along such connections does not contribute parasitic heat flows to the heat flow through the meter section of the specimens and does not significantly perturb the temperature uniformity of the hot plate or the cold plates. Such thermal tempering is not adequate in many guarded hot plate apparatus designs.

Temperature Measurement

In order to obtain accurate thermal transmission data, it is necessary to know accurately the average temperature difference across the meter area of the specimens. This need requires that the surfaces of the meter plates be uniform and stable in temperature and that the temperature sensors adequately sample the meter area if there are significant temperature variations. Most guarded hot plate apparatus use thermocouples to measure hot and cold plate temperatures. Of the standardized thermocouple types, the noble-metal thermocouples (Types B, R, and S) do not have adequate sensitivities to be used at cryogenic temperatures, and the base-metal thermocouples that use iron, copper, or copper-nickel alloys (Types E, J, and T) cannot be used, for long periods of time with fine wire sizes, at the higher temperatures of interest for the new NIST GHP. Thus, of the standardized thermocouples, it would appear to be necessary to select Type K or Type N thermocouples – but both of these thermocouple types have instabilities that limit the accuracy to which temperatures can be measured. (Note that thermocouple departures from calibration do not constitute a serious problem for thermopiles used to control the guard temperature since they are used as null sensors so their actual sensitivity is not critical.) NIST calibrations of Type K and Type N thermocouples, by comparison to a reference thermocouple or a standard platinum resistance thermometer, have expanded uncertainties ($k = 2$) of 0.4 K at 77 K, dropping to near zero at the ice point, and increasing to 0.6 K at 930 K [17-18]. Recently NIST has shown that thermocouples fabricated from pure elements, either gold versus platinum or platinum versus palladium, can be calibrated against fixed point standards with expanded uncertainties ($k = 2$) as small as 10 mK at the highest temperatures of interest for the new NIST GHP [19-21]. Unfortunately, these thermocouples have a very low sensitivity at cryogenic temperatures.

Performance Specifications

The performance specifications for the new NIST GHP are summarized in Table 2. The hot plate will be 500 mm in diameter, which is one of the sizes recommended by ISO 8302 for new apparatus. The meter plate will be 200 mm in diameter to the center of the guard gap, which will be 1.4 mm wide at the hot-plate surfaces. The apparatus will be located in a vacuum chamber that can be filled with dry air or other gases and controlled at constant pressures from a fairly soft vacuum to 1.05 atm. The hot and cold plates will be hung vertically so that the heat flow will be horizontal. The apparatus will accommodate a pair of specimens, each of which can be 10 mm to 110 mm thick, and can be operated in either a 1- or 2-sided mode. The apparatus will be designed to measure the ranges of thermal conductivities and thermal conductances shown in Table 2 at mean temperatures from 90 K to 900 K, with the precisions and uncertainties shown at the bottom of Table 2. In preparing these performance specifications, the highest priorities were assigned to the specimen size, the typical ranges of thermal conductivity and thermal conductances, the temperature range, and the precisions and uncertainties of measurement.

Summary of Design Approach

In response to the design limitations of previous GHPs (Table 1) and the performance specifications (Table 2) that were developed, the following design features were included:

- The hot plate will be of all-metal construction with a multiple-turn swaged meter heater and a multiple-turn swaged guard heater embedded in it. The meter plate and the guard plate will be separated by a diamond-shaped guard gap.
- Each cold plate will be laminated, with a surface plate containing the temperature sensors, a middle plate with a multi-turn swaged heater, and a back plate with a bifilar coolant channel embedded in it, with the three plates separated by thin layers of thermally insulating material.
- Based on the advice of the NIST Thermometry Group, long-stem platinum resistance thermometers (SPRTs) will be used as the primary temperature sensors in the hot plate and the two cold plates. Swaged Type N thermocouples will be provided as secondary temperature sensors. The thermopile across the guard gap will also be of swaged construction, with the thermoelements being Type NP wire versus a 65% Au/35% Pd alloy.
- Two integrated edge guards will be provided, one for each specimen. These edge guards will provide an isothermal environment, nominally at the mean temperature of each specimen.
- Connection guard blocks will be provided to temper the thermometer wells and the heater and sensor leads coming from the hot plate and from both cold plates.
- The hot plate, the two cold plates, and the two edge guards will be suspended vertically from linear ball bushings on rails so that they can be easily moved back and forth to install specimens of various thicknesses.
 - Provision will be made to apply a known axial force to the cold plates.
 - Provision will be made to measure the thickness of the test specimens *in situ*.
 - The entire apparatus will be cantilevered from a vertical vacuum base plate, with a vacuum enclosure that can be rolled into place so that the apparatus can be operated in a vacuum, or operated at a controlled pressure with whatever filler gas is desired. Provision

Table 2 – Design Specifications for the NIST 500 mm Guarded Hot Plate Apparatus

Parameter	Specification		Comment
	Minimum	Maximum	
<i>Hot Plate Size</i>	500 mm round		Per ISO 8302
• Meter Plate	200 mm		Center of gap
• Gap Width	1.4 mm		diamond profile
• Thickness	16 mm		
<i>Specimen</i>			
• Thickness	10 mm	110 mm	
• Conductance	0.1 W/(m ² ·K)	50 W/(m ² ·K)	Design
	0.8 W/(m ² ·K)	8 W/(m ² ·K)	Typical
• Conductivity	0.001 W/(m·K)	0.5 W/(m·K)	Design
	0.01 W/(m·K)	0.2 W/(m·K)	Typical
<i>Temperature</i>			
• Mean	90 K	900 K	
• Hot Plate	95 K	915 K	
• Cold Plate	85 K	885 K	
• Difference	OK	40 K	
<i>Gas Pressure</i>	0.013 Pa	0.105 MPa	10 ⁻⁴ to 790 torr
<i>Operational Mode</i>	1 or 2 sided		
<i>Orientation</i>	Horizontal heat flow		
<i>Precision (90 to 900 K)</i>			
• Single run	0.2 %		k = 2 coverage
• Replicate	0.5 %		k = 2 coverage
<i>Uncertainty</i>			
• 90 K	2 %		k = 2 coverage
• 300 K	1 %		k = 2 coverage
• 900 K	2 %		k = 2 coverage

will be made to clamp the vacuum enclosure to the base plate so that the apparatus can be operated with the chamber pressure somewhat higher than the local barometric pressure.

The proposed overall design of the NIST 500 mm guarded hot plate apparatus, excluding the supporting structure and the vacuum enclosure, is shown in Figure 2. The hot plate itself consists of the 200 mm diameter (to the center of the guard gap) meter plate and the surrounding 500 mm o.d. guard plate. The two specimens are shown cross-hatched. The two cold plate assemblies each move as an integrated unit as do the two donut-shaped edge

guards. The Standard Platinum Resistance Thermometers (SPRTs) used to measure the hot and cold plate temperatures are shown extending to the top of the drawing.

Selection of Plate and Guard Materials

The materials used for the construction of the hot plates, the cold plates, and the edge guards need to have suitable thermal and mechanical properties, good oxidation resistance over the temperature range of interest, and be amenable to the selected method of fabrication. The plates also need to be able to accept and retain a suitable high-emittance coating, as required by C 177 and ISO 8302.

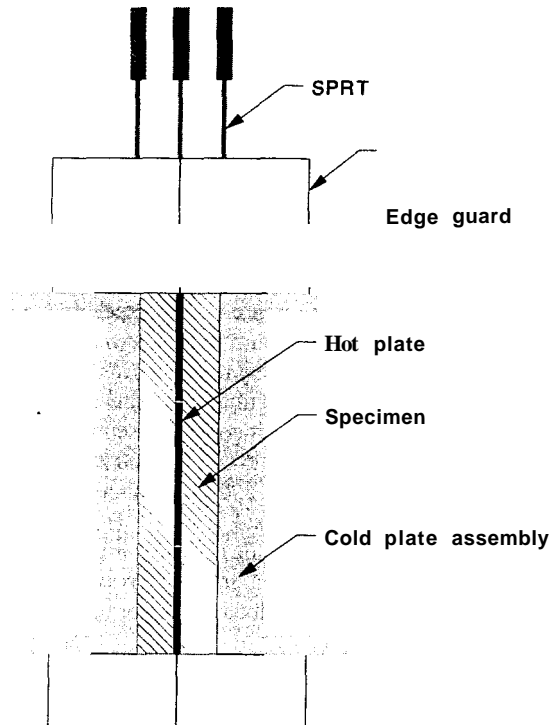

Figure 2 – Configuration of the NIST 500 mm guarded hot plate apparatus

Material Properties

It is desirable for the thermal conductivity of the plate and edge guard material to be as high as possible. In order to achieve thermal equilibrium more rapidly, it is desirable for the plate material to have a low volumetric heat capacity. In general, constructing the plates from a material with a very high thermal conductivity would allow the plates to be thinner, thus further reducing the thermal capacity. However, for the present design, the use of SPRTs as temperature sensors precludes the use of thin hot and cold plates. Some of the advantages and disadvantages of potential plate and guard construction materials are summarized below:

Silver – Silver has the highest thermal conductivity and the lowest volumetric heat capacity of any metal. Its cost would not be excessive when compared with the overall costs of designing, fabricating, and verifying the performance of this new GHP. The strength of silver is rather low but would appear to be adequate. A major problem with silver, for the higher temperatures of interest in this project, is that it forms a volatile oxide so that any high-emittance coating would not continue to adhere to the plates. In principle, silver could be protected from oxidation by applying a heavy electroplated coating of, e.g., gold or nickel.

Copper – Copper has a thermal conductivity similar to that of silver, but has a significantly higher volumetric heat capacity and, in addition, would have to be heavily coated, e.g., by nickel, silver, or gold plating, to provide protection against oxidation. Consultations with NIST metallurgists did not achieve consensus as to whether or not copper could be adequately protected against oxidation for long periods at elevated temperatures, or consensus as to the best means of providing oxidation protection.

Gold – Gold has a thermal conductivity somewhat lower than that of silver and copper and a volumetric heat capacity essentially identical to that of silver and copper. Gold is impervious to oxidation. It apparently is very difficult to get high-emittance coatings to adhere to gold. In any case, gold is too expensive to be used for this project.

Aluminum – Aluminum has a thermal conductivity about half that of silver and copper, and could be used only to about 700 K (the melting point of aluminum is 933 K).

Nickel – Nickel has a thermal conductivity much lower than those of the other pure metals discussed above, but it could be used in air over the temperature range of interest.

Metallic Oxides – Below about 800 K, the thermal conductivity of beryllium oxide is higher than that of nickel, and below about 200 K its thermal conductivity is as high or higher than that of silver and copper. However, at higher temperatures, the thermal conductivity of beryllium oxide is quite low compared to the pure metals. Aluminum oxide is even worse. In addition, metallic oxides would require quite different fabrication techniques from those described below for use with metals.

Means of Fabrication

As discussed below and in the companion paper [16], it is important to have the heaters located accurately in the hot and cold plates in order to obtain optimally isothermal conditions. After reviewing alternative methods of fabrication that would ensure accurate positioning, it was decided to make the hot plate from two halves brazed together, with swaged heater elements brazed into grooves machined in one half. This type of construction should provide excellent conductive heat transfer while avoiding outgassing problems. The cold plate heaters will be brazed into grooves in a “heater plate,” as described further below. Alternative means of fabrication that would result in a swaged heater being embedded in a plate include casting, electroforming, electrical deposition, or hot isostatic pressing.

Selected Material

The final candidates for the material from which to fabricate the hot and cold plates and the edge guards were (1) nickel and (2) nickel-plated copper. If the SPRTs were not being used, the plates could have been made thinner and the higher thermal conductivity of copper would have helped ensure that the plates were adequately isothermal. However, the use of SPRTs mandated the use of thick plates that, with appropriate heater design, will have sufficient lateral thermal conductance to be adequately isothermal even when fabricated from nickel, with its much lower thermal conductivity. The use of nickel avoids the need of providing a thick electroplated coating over copper, with the attendant risks of flaws that could allow potentially serious oxidation of the copper. The plates and the edge guard are thus being fabricated from Alloy 201, a commercially pure nickel with a low carbon content

and good oxidation resistance. The commercial swaged heating elements have an Alloy 600 sheath. The brazing alloy is a nickel-phosphorous eutectic alloy that is known to work extremely well with nickel and to adhere well to Alloy 600.

Hot Plate Design

The geometrical layout of the guarded hotplate is shown in Figure 3. A major difference from the designs of other guarded hot plates is that the thermometer well, heater leads, and thermocouple and thermopile leads are thermally grounded to a “connection guard block” that is provided with a heater and a coolant coil so that it can be maintained at the same temperature as the meter and guard plates. This connection guard block is particularly important in order to avoid perturbing the temperature distribution in the guard plate due to heat conduction along the thermometer well and the swaged leads, which are more conductive than is the case for most previous designs.

Figure 4 shows the type of heater layout that might be used in the meter plate for a guarded hot plate that uses thermocouples as temperature sensors. The switchback bends in this layout are located such that the total length of heater is the same as it would be for five circular heaters, located at the recommended radii from C 1043. Thus there might be local hot and cold spots, relative to the temperature distribution that would be obtained with circular heaters, but the overall temperature uniformity of the meter plate would be similar to what it would be for circular heaters [16]. This heater layout is not suitable for use with a long-stem platinum resistance thermometer, however, since the sensitive portion of the SPRT would be located too close to the heater. For the new NIST guarded hot plate apparatus, the heater layout will be as shown in Figure 5. A bifilar swaged heater will be brazed into grooves in one half of the meter plate, as shown at the bottom of Figure 5, and

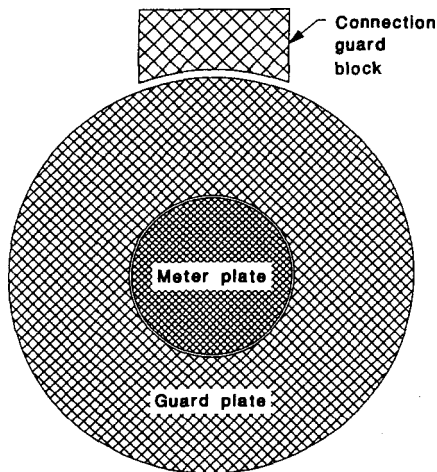

Figure 3 – Overall layout of hot plate

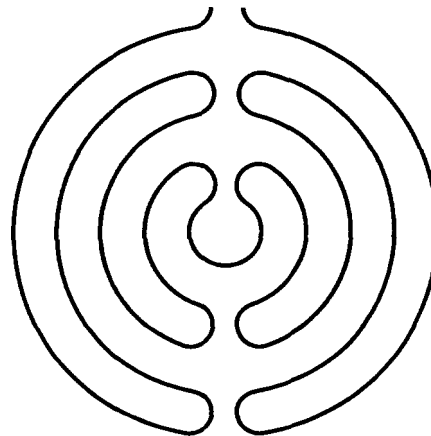

Figure 4 – Meter plate heater layout for use with thermocouples

the two halves of the plate will be brazed together. This heater layout provides an open “corridor” for the SPRT, the sensitive portion of which is shown as a darker gray than the insensitive portion [16]. A thermometer well will be brazed into the meter and guard plates, with a vacuum-tight O-ring seal at the top. The thermometer well will be provided with a side connection so that it can be filled with helium to provide better thermal coupling to the SPRT.

The layout of the guard plate heater, which is also a bifilar, swaged heater, is shown in Figure 6. The straight section of heater running from the inside of the guard plate to outside the top of the guard plate, just to the right of the centerline, contains the leads to the meter plate heater. The guard heater layout has been designed to allow for the heat generated in the leads to the meter plate heater. There also will be an edge heater, not shown in Figure 6, to compensate for heat loss to the edge guards.

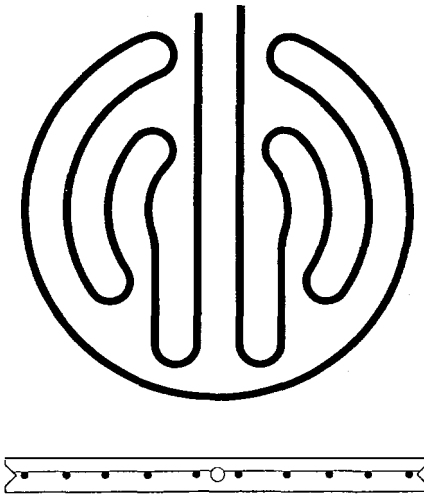

Figure 5 – Meter plate heater layout for use with SPRTs.

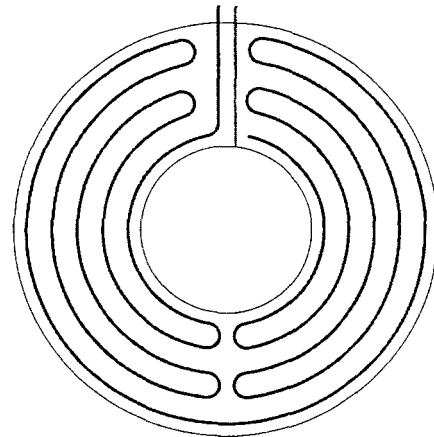

Figure 6 – Guard plate heater layout

Cold Plate Design

Each cold plate assembly will be laminated, with a surface plate that accommodates the SPRT, a thin layer of insulation, a heater plate with a swaged heater element similar to that shown in Figure 4, but with more turns, another thin layer of insulation, a coolant plate, with a bifilar channel to accommodate liquid nitrogen or ethanol as a coolant, a thick layer of insulation, and a waterjacket to provide a constant temperature environment and to protect personnel from contact with hot or cold surfaces [16]. Each cold plate assembly will be provided with a connection guard block, similar to that discussed above for the hot plate. Each cold plate assembly will be an integral unit, so that when installing test specimens, it

will not be necessary to deal separately with the various components or to use loose-fill insulation. As shown in Figure 2, there is an extra annulus of insulation behind the outer edge of each cold plate assembly, in order to provide insulation of the inside surface of the edge guard when thinner specimens are tested.

Thermometry

As stated above, based on discussions with the NIST Thermometry Group, the primary measurements of the hot plate and cold plate temperatures will be made using three long-stem platinum resistance thermometers that have been calibrated by NIST. The bridge used to measure the thermometer resistances is of the same type used for calibrating SPRTs in many national standards laboratories and will provide a resolution of 1 mK.

The hot plate and the two cold plates will also be provided with swaged, Type N thermocouples to provide information as to how accurately plate temperatures could be measured if the SPRTs were not used. This information should be useful to laboratories that might wish to copy aspects of the present design for a guarded hot plate apparatus but that do not wish to incur the expense of SPRTs and a bridge. The edge guards will be provided with the same type of thermocouples. Type T thermocouples will be used to monitor water jacket and support structure temperatures. The leads from all thermocouples will be brought to an isothermal junction box where they will be connected to leads, from the same lot of thermocouple wire, that pass through vacuum seals to an isothermal zone box, whose temperature will be measured using a calibrated capsule platinum resistance thermometer. Thus if it is necessary to replace a thermocouple in the apparatus, it is not necessary to make a new vacuum seal. All thermocouple voltages will be read using a low-thermal-emf switch system and a high-accuracy digital voltmeter.

For the guard gap thermopile, it is important to have a high sensitivity but it is not necessary that the sensitivity be accurately known, since the thermopile operates as a null control sensor. Type E (nickel-10% chromium versus nickel-45 % copper) thermocouples have the highest sensitivity of the common letter-designated thermocouples. However, the nickel-45 % copper alloy oxidizes too easily for fine wire sizes to be used at the highest temperatures of interest for this project. For the new NIST guarded hot plate apparatus, the thermopiles will use Type KP (nickel-10 % chromium) wire for the positive leg and a gold-35 % palladium alloy for the negative leg. Such a combination has a sensitivity similar to that of Type E thermocouples but can withstand much higher temperatures. The leads from the guard plate to room temperature will be constructed of a pure element (platinum, gold, or palladium) to minimize spurious thermal emfs that might otherwise arise if an alloy were used for the leads. The two thermopiles across the guard gap will also be of swaged construction and will be brazed into grooves cut in the surfaces of the hot plate.

Edge Guards

For the new NIST GHP, relatively tight-fitting edge guards will be used, with 10 mm of edge insulation between the outer edge of the hot and cold plates and the inner surface of the edge guards [16]. As indicated in Figure 2, there will be two doughnut-shaped edge guards, one surrounding each specimen. Each edge guard will have a "bite" taken out of it

at the top where the connection guard blocks are located (see Figure 3). Each edge guard will consist of an inner nickel ring with a swaged heater brazed into it, a thin layer of insulation, a second nickel ring provided with cooling coils, a thick layer of insulation, and an outer water jacket to keep the exposed surface of the edge guard at room temperature. The nickel rings will be wider than the thickest specimens for which the apparatus is designed.

Secondary Systems

Suspension System

The vacuum base plate will be vertically oriented, with three pairs of horizontal rails cantilevered from it to support the key components of the guarded hot plate apparatus. The hot plate is suspended from pillow blocks with bearings that ride on the innermost pair of rails. The two cold plate assemblies are similarly suspended from the second pair of rails and the two edge guard assemblies hang from the outer pair of rails.

Force Application

The cold plate assembly that is furthest from the vertical baseplate will be fixed in place by a stanchion that can be moved along a slide to accommodate specimens of different thickness and then locked down. A system of weights and a lever arm will be used to apply a known force to the back of the other cold plate assembly. Conceptually, the force-application system will be similar to a mechanical beam balance, with lever arms to amplify the force and apply it to the back of the moveable cold plate assembly.

Thickness Measurement

Specimen thickness will be measured using displacement sensors at room temperature, with the positions of the cold plates being brought out to room temperature using fused quartz rods in a manner analogous to single pushrod dilatometry. Two displacement transducers will be used, each being mounted on a stanchion provided with kinematic mounts such that the stanchion can be removed and replaced in the same location within about $1\ \mu\text{m}$. The bases to which the stanchions are attached ride on an invar U-frame that is not subjected to external forces. In use, the movable stanchion base will be clamped down to the invar frame at a position appropriate for the specimen thickness to be tested. Gage blocks of length similar to that of the specimens to be tested would be inserted between the hot plate and each of the cold plates, providing a calibration of the combined tare for the two displacement transducers. The stanchions will be removed while the specimens are installed and then replaced at the same position, thus allowing determination of any changes in combined specimen thickness as a function of test temperature.

Environmental Control System

The NIST 500 mm guarded hot plate apparatus ultimately will be enclosed in a chamber consisting of a vertical metal baseplate, to which the apparatus is attached, and a cylindrical

metal bell jar that lies on its side, in a movable cart, so that the flange holding the captive O-ring is in a vertical plane. The requirements for this atmospheric control system include:

- Capability to pump the system down to 0.01 Pa, starting with any of a range of gases in the chamber
- Capability to pump down very slowly with the mechanical vacuum pump so that powdered or fibrous specimens will not be sucked out of the chamber
- Fully automated pump-down of the chamber
- Capability to clamp the bell jar to the baseplate so that the system can be pressurized up to 0.105 MPa absolute, regardless of the ambient barometric pressure
- Capability to backfill the chamber with various gases, and to control the chamber pressure at any desired pressure from 0.01 Pa to 0.105 MPa while the temperatures inside the guarded hot plate apparatus vary.

Summary

The new NIST 500 mm GHP that is described in this paper provides new design concepts for a guarded hot plate apparatus that complies with the requirements of C 177 and ISO 8302, while offering several design advantages, relative to prior designs, that will result in very good measurement accuracy over a broad temperature range and under controlled gas pressure. These design concepts include:

- A solid nickel guarded hot plate with embedded meter plate and guard plate heaters designed so that the temperature distribution in the plates can be calculated and the average temperature in the meter plate can be accurately determined.
- A laminated cold plate construction with the heaters and coolant lines in different nickel plates (from the surface plate) so as to minimize temperature variations across the cold plates.
- Rugged swaged heaters and thermocouples in all components of the apparatus, and a swaged thermopile across the guard gap.
- The use of long-stem platinum resistance thermometers as the primary temperature sensors in the hot plate and the two cold plates, thus providing greatly improved accuracy in temperature measurement, relative to what could be attained with thermocouples.
- The use of integrated edge guards that have been designed to minimize errors due to edge heat loss or gain.
- The use of connection guard blocks to minimize the effects of parasitic heat flows along thermometer wells and heater and sensor leads.
- Provision to provide a controlled, accurately known force to the cold plates.
- Provision to make accurate *in situ* measurements of specimen thickness, while using kinematic mounts to allow removal of the displacement sensors during specimen installation.
- Enclosure of the GHP inside a vacuum enclosure so that the apparatus can be operated in a vacuum, or operated at any desired controlled pressure with whatever filler gas is desired.
- An overall design that allows accurate measurements from 90 K to 900 K, without any need to open up the apparatus or to change components.

References

- [1] Hust, J. G., and Smith, D. R., "Round-robin Measurements of the Apparent Thermal Conductivity of Two Refractory Insulation Materials, Using High-Temperature Guarded-Hot-Plate Apparatus," Report No. NBSIR 88-3087, National Bureau of Standards, Boulder, CO, April 1988, 27 pp.
- [2] Salmon, -D. R., and Tye, R. P., "A High Temperature Guarded Hot Plate Intercomparison," to be published in *Thermal Conductivity 26/ Thermal Expansion 14*, R. Mannello, Ed., Technomic Publishing Co, Lancaster, PA, 2002.
- [3] Robinson, H. E., "Line Heat Source Hot Plates for Measuring the Thermal Conductivity of Insulations," unpublished paper presented at the Thermal Conductivity Conference held at the National Physical Laboratory, United Kingdom, in July 1964.
- [4] Tye, R. P., "Thermal Conductivity," *Nature*, vol. 204, 1964, pp. 636-637.
- [5] Flynn, D. R., Robinson, H. E., and Watson, T. W., "Progress Report: National Bureau of Standards," in *Proceedings 4th Conference On Thermal Conductivity* (Limited distribution), U.S. Naval Radiological Defense Laboratory, San Francisco, CA, October 1964, pp. VIII-NBS-1 to VIII-NBS-14.
- [6] Hahn, M. H., "The Line Source Guarded Hot Plate for Measuring the Thermal Conductivity of Building and Insulating Materials," Ph.D. Dissertation, Catholic University of America, Washington, DC, 1971.
- [7] Hahn, M. H., Robinson, H. E., and Flynn, D. R., "Robinson Line-Heat-Source Guarded Hot Plate Apparatus," in *Heat Transmission Measurements in Thermal Insulation, ASTM STP 544*, R. P. Tye, Ed., American Society for Testing and Materials, Philadelphia, 1974, pp. 167-192.
- [8] Powell, F. J. and Siu, M. C. I., "Development of the Robinson Line-Heat-Source Guarded-Hot-Plate Apparatus for Measurement of Thermal Conductivity," in *Proc. XIV International Congress of Refrigeration*, Vol. 2, International Institute of Refrigeration, Paris, France, 1975, pp. 536-542.
- [9] Siu, M. C. I. and Bulik, C., "National Bureau of Standards Line-Heat-Source Guarded-Hot-Plate Apparatus," *Rev. Sci. Instrum.* Vol. 52, 1981, pp. 1709-1716.
- [10] Siu, M. C. I., "Comparison of Results of Measurements Made on a Line-Heat-Source and a Distributed-Heat-Source Guarded-Hot-Plate Apparatus," in *Thermal Conductivity 17*, J. G. Hust, Ed., Plenum Press, New York, 1983, pp. 413-426.
- [11] Powell, F. J. and Rennex, B. G., "The NBS Line-Heat-Source Guarded Hot Plate for Thick Materials," *Proceedings ASHRAE/DOE Conference On Thermal Performance of Exterior Envelopes of Buildings II, ASHRAE SP 38*, American Society of Heating, Refrigerating and Air-conditioning Engineers, Atlanta, GA, 1983, pp. 657-672.

- [12] Rennex, B. G., "Error Analysis for the NBS 1016 mm Guarded Hot Plate," *J. Thermal Insulation*, Vol. 7, 1983, pp. 18-51.
- [13] Rennex, B., "Summary of Error Analysis for the National Bureau of Standards 1016-mm Guarded Hot Plate and Considerations Regarding Systematic Error for the Heat Flow Meter Apparatus," in *Guarded Hot Plate and Heat Flow Meter Methodology, ASTM STP 879*, C. J. Shirliffe and R. P. Tye, Eds., American Society for Testing and Materials, Philadelphia, 1985, pp. 69-85.
- [14] Rennex, B. G., "An Assessment of the NBS 1-m Guarded-Hot-Plate Limits," Rept. No. NBSIR 85-3221, National Bureau of Standards, Gaithersburg, MD, August 1985, 97 pp.
- [15] Zarr, R. R. and Hahn, M. H., "Line-Heat-Source Guarded-Hot-Plate Apparatus," Adjunct to ASTM C 1043-97, December 1995. (Available from American Society for Testing and Materials, 100 Barr Harbor Drive, West Conshohocken, PA 19438-2959. Request PCN No. 12-310430-61.)
- [16] Healy, W. M. and Flynn, D. R., "Thermal Modeling of a New Guarded Hot Plate Apparatus," *Insulation Materials: Testing and Applications: 4th Volume, ASTM STP 1426*, A. O. Desjarlais and R. R. Zarr, Eds., ASTM International, West Conshohocken, PA, 2002.
- [17] Ripple, D. Bums, G. W., and Scroger, M. G., "Assessment of Uncertainties of Thermocouple Calibrations at NIST," Report No. NISTIR 5340, National Institute of Standards and Technology, Gaithersburg, MD, January 1994. 34 pp.
- [18] Mangum, B. W., Furukawa, G. T. K., Kreider, G., Meyer, C. W., Ripple, D. C., Strouse, G. F., Tew, W. L., Moldover, M. R., Johnson, B. Carol, Yoon, H. W., Gibson, C. E., and Saunders, R. D., "The Kelvin and Temperature Measurements," *J. Res. Natl. Inst. Stand. Technol.*, Vol. 106, 2001, pp. 105-149.
- [19] Bums, G. W., Strouse, G. F., Liu, B. M., and Mangum, B. W., "Gold versus Platinum Thermocouples: Performance Data and an ITS-90 Based Reference Function," in *Temperature: Its Measurement and Control in Science and Industry*, Vol. 6, J. F. Schooley, Ed., American Institute of Physics, New York, NY, 1992, pp. 531-536.
- [20] Burns, G. W. and Ripple, D. C., "Techniques for Fabricating and Annealing Pt/Pd Thermocouples for Accurate Measurements in the Range 0 °C to 1300 °C," in *Proceedings of TEMPMEKO '96, 6th International Symposium on Temperature and Thermal Measurements in Industry and Science*, P. Marcarino, Ed., Levrotto & Bella, Turin, Italy, 1997, pp. 171-176.
- [21] Bums, G. W., Ripple, D. C., and Battuello, M., "Platinum versus Palladium Thermocouples: An Emf-Temperature Reference Function for the Range 0 °C to 1500 °C," *Metrologia*, Vol. 35, 1998, pp. 761-780.