

DRAFT: HT2003-40567

HEAT FLUX SENSOR WITH MINIMAL IMPACT ON BOUNDARY CONDITIONS

Arash Saidi,
ATEC Inc.
387 Technology Dr.,
College Park, MD 20742

Jungho Kim,
Dept. of Mechanical Engineering
University of Maryland
College Park, MD 20742

ABSTRACT

A technique for determining the heat transfer on the far surface of a wall based on measuring the heat transfer and temperature on the near wall is presented. Although heat transfer measurements have previously been used to augment temperature measurements in inverse heat conduction methods, the sensors used alter the heat flow through the surface, disturbing the very quantity that is desired to be measured. The ideal sensor would not alter the boundary condition that would exist were the sensor not present. The innovation of this technique in that it has minimal impact on the wall boundary condition. Since the sensor is placed on the surface of the wall, no alteration of the wall is needed. The theoretical basis for the experimental technique as well as experimental results showing the heat flux sensor performance is presented.

NOMENCLATURE

q	Heat flux value
T	Temperature
h	Coefficient of heat transfer
S	Sensitivity to errors

Subscripts

1	Inaccessible surface
2	Accessible surface
h	Active sensor (heater)
s	Surface
c	Cooler device
x	Unknown heat flux
•,h	Bulk temperature of water in cooler
•,s	Bulk temperature of air

INTRODUCTION

Inverse heat conduction methods can be used to determine heat flux and temperatures on an inaccessible surface of a wall by measuring the temperature on an accessible boundary (TS method, Figure 1a). The noise present in any measure of temp-

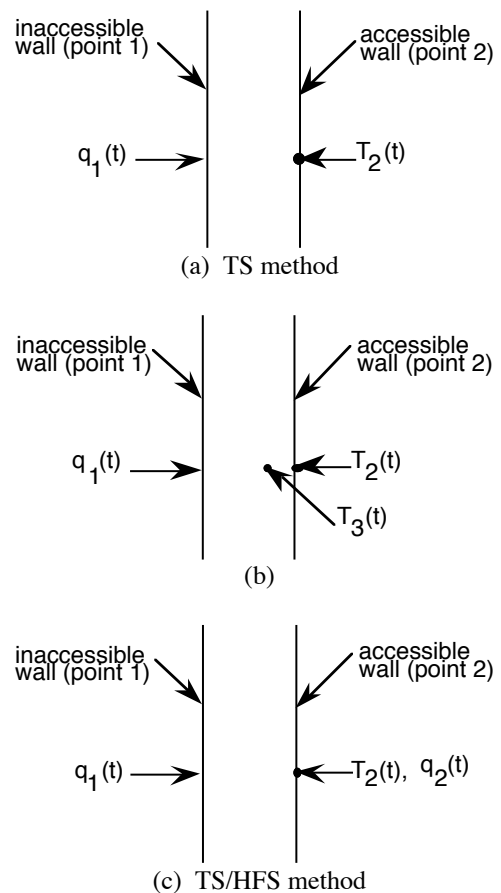

Figure 1: Schematic of inverse heat conduction methodologies.

erature, however, can cause instabilities in the predicted heat fluxes. It has been shown [1] that the prediction can be greatly improved by measuring temperature at two locations (Figure 1b). Altering the wall to include an interior thermocouple cannot be performed in many applications, and installation of an interior thermocouple can result in material inhomogeneities that change the heat flow through the wall. By numerical

experiments and a sensitivity analysis we show that incorporating a measurement of the heat flux at the accessible boundary (TS/HFS method, Figure 1c) can be used to improve the calculation.

The objective of this work was to develop a method by which stable predictions of the heat transfer on an inaccessible boundary could be obtained without altering the thermal boundary condition that would have existed were a sensor not present. As mentioned above, it is known that increasing the number of the sensors will enhance the stability of the inverse solution by incorporating more data about the heat flux at the inaccessible boundary. An alternative to inserting a thermocouple within the wall is to measure the heat flux at the accessible surface. It will first be shown below via numerical experiments with an inverse method that this extra input (heat flux) increases the stability of the procedure and is less prone to the inherent instability of the ill-posed problem of inverse heat conduction. A sensitivity analysis is then carried out to show that the inverse conduction results are less sensitive to errors in heat flux sensors values than errors in temperature input. A sensor that measures both heat transfer and temperature on an accessible boundary with minimal impact on the boundary condition is then described and results of experiments with this sensor are presented.

NUMERICAL EXPERIMENTS

In order to demonstrate the advantage of using both heat flux and temperature data at an accessible boundary to predict heat transfer at an inaccessible boundary, a program was developed that uses both temperature and heat flux data on an accessible boundary (point 2) to estimate the heat flux at an inaccessible boundary (point 1).

A series of numerical experiments were conducted. In the first of these efforts, we calculated the heat flux at point 1 using two methods, one using only temperature sensor data and the other using both temperature and heat flux data at point 2.

These data were artificially generated from a solution of the problem assuming the exact input at point 1. The heat conduction equation was then solved to determine the temperature at point 2. To simulate the effect of the actual errors in temperature, a random number generator was used to generate random numbers between 0 and 1. These numbers were multiplied by a percentage (5, 8 and 12%) of the exact value and added to this value.

It was noticed that the TS/HFS method resulted in a more accurate estimation of the heat flux at far boundary (q_1) than the TS method. In order to quantify this effect an error value was defined:

$$\text{Error} = \frac{\overline{\Delta q_1}}{q_1} \quad (1)$$

where, $\overline{\Delta q_1}$ is the average of the absolute difference between estimated and exact values of q_1 over the whole time domain. This normalized value with calculated respect to input error in the temperature and heat flux values. The results are shown in

Figure 2. This figure shows that the TS/HFS method decreases the error levels considerably. For a 12% error (in temperature at point 2), the average error in the estimated value of q_1 is about 85% of the average value for the TS method while it is about 42% for the TS/HFS method, demonstrating the superiority of the mixed method with respect to errors in estimated heat flux values.

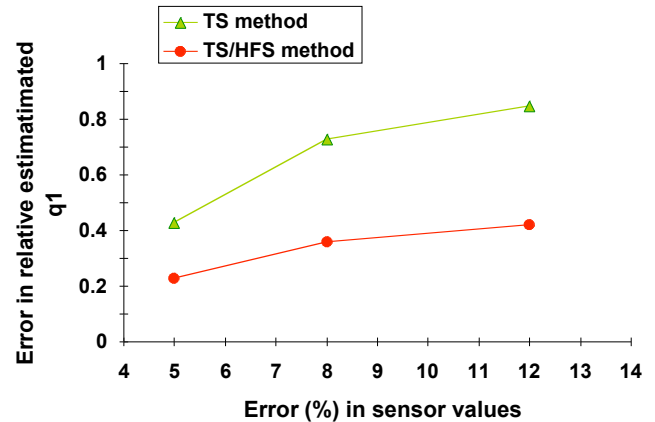

Figure 2: Relative effect of erroneous data on estimated q_1 values.

In order to investigate this effect, the errors in temperature (T_2) and heat flux input (q_2) data were separated and the sensitivity of q_1 to each of these inputs in one case was analyzed. The sensitivity of the estimated values to each of these inputs was defined as:

For T_2 :

$$S_{T_2} = \frac{\overline{\Delta q_1} / \overline{q_1}}{\overline{\Delta T_2} / T_2} \quad (2)$$

For q_2 :

$$S_{q_2} = \frac{\overline{\Delta q_1} / \overline{q_1}}{\overline{\Delta q_2} / q_2} \quad (3)$$

These values indicate how sensitive the estimated values of q_1 are to the relative errors in input values separately. The values for the same problem discussed above were recalculated resulting in these values for S_{T_2} and S_{q_2} :

$$S_{T_2} = 13.7$$

$$S_{q_2} = 1.4$$

It is evident from this sensitivity study that the errors in estimation of heat flux at a far boundary (q_1) is one order of magnitude more sensitive to errors in a temperature sensor than to errors in heat flux at point 2, demonstrating the importance of incorporating heat flux data in the inverse heat conduction estimation process.

PROPOSED HEAT FLUX SENSOR

Several heat flux sensors have been developed to measure the thermal radiation in aerodynamic flows. For example, Borell and Diller [2] designed an apparatus for measuring heat fluxes

in convective airflows. A different type of heat flux sensor was developed by Hager *et al.* [3], which consisted of several layers of thin films that form a differential thermopile across a thin oxide layer. A sensor developed by Leclercq and Thery [4] measured the heat flux by determining the temperature gradient over a tangent plane to the heat flux surface. Physical asymmetries are used to deflect the heat flux lines and generate a temperature gradient over a planar thermopile. This gradient is directly proportional to the imposed heat flux and produces a voltage across the thermopile. A number of such thermopiles are fabricated in series to amplify the voltage proportional to the heat flux.

Any heat flux sensor is only able to measure the heat transfer through it. All of the sensors described above alter the heat flow through the surface, disturbing the very quantity to be measured. The ideal sensor would minimally alter the boundary condition that would exist were the sensor not present. Such a sensor can be made using the concept described below.

A schematic diagram of the sensor is shown on Figure 3. A small resistance heater (“Active heater” in Figure 3) is attached to the accessible boundary of a wall, and its temperature is controlled by an electronic feedback loop to track the temperature of a passive temperature sensor (“Passive sensor” in Figure 3) mounted on the same boundary a short distance away. The passive temperature sensor is very thin so the wall boundary condition is only minimally altered. The active heater is cooled by an efficient and substantial cooling mechanism from behind (for example, circulating chilled water or an impinging air or water jet).

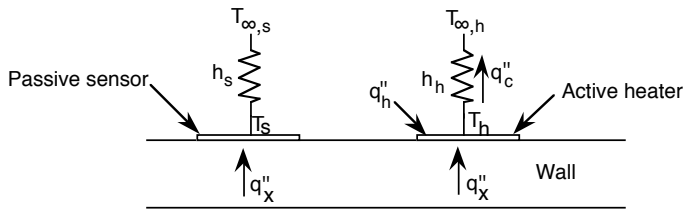

Figure 3: Schematic representation of heat flux sensor.

By measuring the heat added to the active heater (q_h in Figure 3), we can determine the heat flux through the wall q_x as shown by the simple analysis of the heat flux sensor performance given below. The passive temperature sensor is cooled through convection by a heat transfer coefficient h_s . An energy balance on this sensor yields

$$q_x = h_s (T_s - T_{\infty,s}) \quad (4)$$

Solving for the passive sensor temperature yields

$$T_s = \frac{q_x}{h_s} + T_{\infty,s} \quad (5)$$

An energy balance on the active heater is given by

$$q_x + q_h = q_c \quad (6)$$

Where

$$q_c = h_h (T_h - T_{\infty,h}) \quad (7)$$

If the heater temperature T_h is kept at the same temperature as the sensor (this is done using a feedback circuit as described below), then $T_h = T_s$ and Eq (5) and (7) can be substituted into Eq. (6) to yield

$$q_h = q_x \left[\frac{h_h}{h_s} + 1 \right] + h_h (T_{\infty,s} - T_{\infty,h}) \quad (8)$$

Examination of Eq. (8) indicates the following properties of the heat flux sensor:

1). If the heat transfer coefficients (h_s and h_h) and the environment and coolant temperatures ($T_{\infty,s}$ and $T_{\infty,h}$) are constant and $h_h > h_s$, then the heat supplied to the heater is linearly proportional to the heat transfer through the substrate.

By measuring q_h , q_x can be determined.

2). If h_h is larger than h_s , the heat flux sensor acts to amplify the heat transfer through the wall by an amount

$$\left[\frac{h_h}{h_s} + 1 \right]$$

without disturbing the wall temperature.

3). In order to avoid the possibility of negative q_h , we should keep $T_{\infty,s} > T_{\infty,h}$ and $h_h/h_s > 1$.

4). If h_s and h_h are constant, then drifts in $T_{\infty,s}$ and $T_{\infty,h}$ simply result in an offset to q_h . The heat flux sensor can be operated with different $T_{\infty,s}$ and $T_{\infty,h}$ by using Eq. 8 to correct the output.

A schematic of the electronic feedback circuit is shown on Figure 4. The voltage applied to the active heater is controlled using a feedback control circuit similar to that described by Bae *et al.* [5]. This circuit maintains the temperature of the active heater equal to the temperature of the passive sensor. The op-amp in the control circuit measures the imbalance in the bridge and outputs the voltage needed to keep ratio R_{active}/R_u equal to the resistance ratio on the right side of the bridge. The heater resistance (R_{active}), and thus the heater temperature are controlled by changes in the resistance of the passive sensor ($R_{passive}$) due to temperature changes on the surface of the wall. The voltage across the heater (V_{out}) is measured and used to determine q_h . The resistance of the passive sensor can be determined by measuring V_A and the current through the small resistor $R_{passive,0}$. Since the temperature of the active heater tracks the temperature of the accessible boundary (as measured by the passive heater), the presence of the active heater and the cooling of this heater do not alter the thermal boundary condition on this boundary.

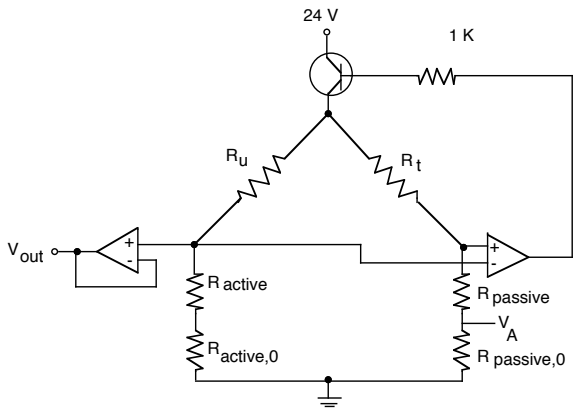

Figure 4: Electronic feedback loop to control heater resistance.

The sensor described above is preferable to other heat transfer measuring systems for the following reasons:

- The sampling rate of each heater can reach a frequency as high as 15 kHz, allowing for rapid temporal discrimination of changes in heat flux, if needed.
- The measurement technique is capable of handling high temperatures.
- The incorporation of a feedback loop to maintain the temperature of the heater at the same temperature as the surface that is undisturbed by the active sensor eliminates the problem of sensor-structure interaction that can occur with other heat flux sensing techniques and the resulting heat flux errors.
- Unlike thin film sensors, the output of this sensor is directly measurable, with no need for amplification by using either a series of sensors and/or amplifiers.
- The proposed sensor can be easily designed to survive hostile environments.

HEAT FLUX SENSOR PERFORMANCE

The concept has been tested using the setup shown in Figure 5.

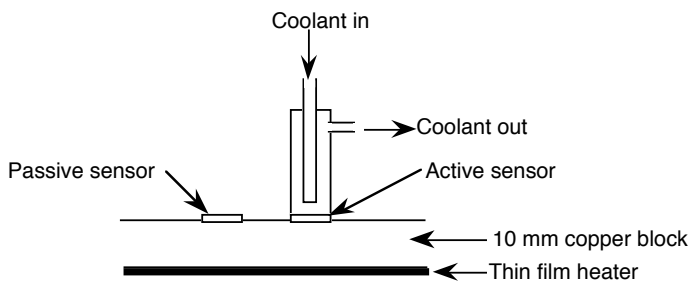

Figure 5: Schematic of test rig.

A 5.2 cm x 7.6 cm copper plate 10 mm thick was used for the wall, and heated using a Minco foil heater connected to a variable voltage source. A pair of RTDs for the active and passive sensor were specially made for this application by Vishay Electronics. The RTDs consist of a 2.54 μm thick etched platinum foil sandwiched between two 0.0254 mm thick Kapton films. The passive and active sensor resistances were 988.9 Ω and 98.6 Ω at 20 °C. The RTDs had a nominal TCR

of 0.0035 Ω/Ω°C with dimension 10 mm x 5 mm. The active sensor was cooled from the back using an impinging jet of water at a constant flow rate (160 ml/min) and temperature (30 °C) to provide a high h_h , and a fan was used to provide a constant h_s to cool the plate. The air and water inlet temperatures ($T_{\infty,=25}$ °C and $T_{\infty,h}=30$ °C) were measured along with the voltage across the heater (V_{out}) as q_x was increased to verify that they remained constant. A plot of q_h vs. q_x is shown on Figure 6, and indicates a linear variation as expected. The sensitivity is seen to be quite high.

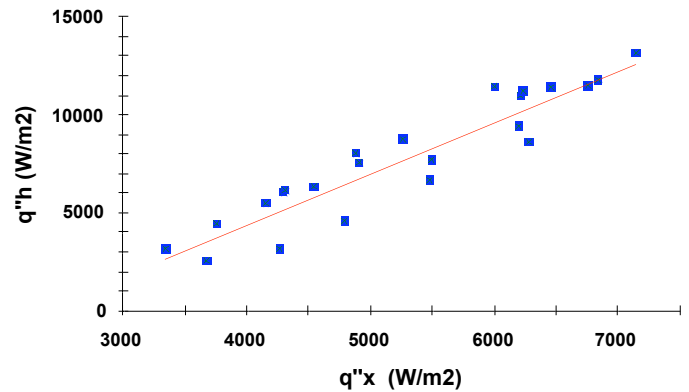

Figure 6: A plot of q_h vs. q_x .

The results of the steady state heat flux measurement using the sensor as the voltage across the foil heater was increased are shown on Figure 7. The actual heat flux values were computed using the measured voltage across the foil heater and its resistance, while the sensor values were obtained using the feedback circuit. The agreement is observed to be well within 10%.

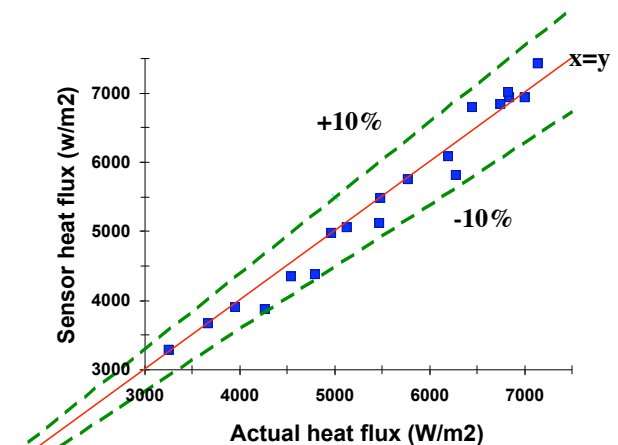

Figure 7: Comparison of actual heat flux into the copper plate vs. the heat flux measurement using the active and passive sensors.

This sensor was then used to estimate the transient heat flux into the inaccessible side of the 10 mm thick copper slab for the case where the input heat flux was suddenly decreased from 6500 W/m² to 0 W/m². The heat flux sensor provided heat flux

and temperature data on the accessible side of the copper slab, and the inverse heat conduction model and software were used to estimate the heat flux variation with time on the inaccessible side. These results are presented in Figure 8. The estimated heat flux agrees very well with the actual heat flux variation.

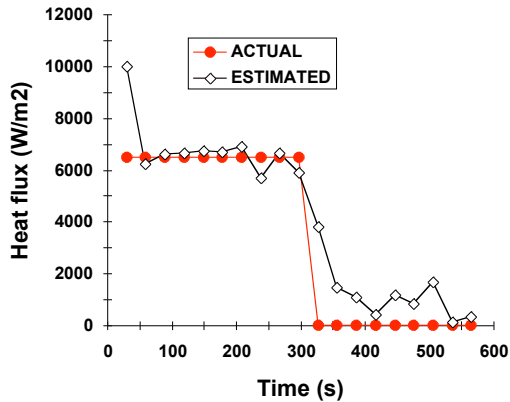

Figure 8: Estimated heat fluxes (Heat flux decreased from 6500 W/m² to 0 W/m²)

CONCLUSIONS

The advantage of incorporating heat flux into an inverse heat conduction method for predicting heat fluxes on an inaccessible wall was confirmed via numerical experiments. A novel heat flux sensor that has a minimal effect on the wall thermal boundary condition has been designed and built. Experiments were conducted to verify the feasibility and accuracy of the concept. It was observed that the proposed sensor is quite sensitive to the input heat flux value and possesses good accuracy. In this stage of our effort, other problems associated

with the sensor such as the surface conditions and the temporal response of the cooling device were not considered. These issues can affect repeatability of the sensor and time response of it to changes, but they do not alter the main conclusions of this study.

ACKNOWLEDGMENTS

The support of Kirtland AFB under SBIR F29601-02-C-0138 is gratefully acknowledged. The grant monitor was Dr. Choon Tham.

REFERENCES

- [1] J.V. Beck, B. Blackwell and C. St. Clair Jr., *Inverse Heat Conduction: Ill-posed Problems*, Wiley, New York, 1985.
- [2] G.J. Borell and T.E. Diller, A Convection Calibration Method for Local Heat Flux Gages, *ASME Transactions Journal of Heat Transfer*, **109**, pp. 83-89, 1987.
- [3] J.M. Hager, L.W. Langley, S. Onishi and T.E. Diller, Microsensors for High Heat Flux Measurements, *Journal of Thermophysics and Heat Transfer*, **7**, no. 3, pp. 531-534, 1993.
- [4] D. Leclercq and P. Thery, Apparatus for Simultaneous Temperature and Heat Flux Measurements under transient Conditions, *Rev. Sci. Instrum.*, **54**, pp. 374-380, 1983.
- [5] S. Bae, M.H. Kim and J. Kim, Improved Technique to Measure Time and Space Resolved Heat Transfer under Single Bubbles during Saturated Pool Boiling of FC-72, *Experimental Heat Transfer*, **12**, No. 3, pp. 265-278, 1999.