

See discussions, stats, and author profiles for this publication at: <http://www.researchgate.net/publication/275659160>

# Combined Guarded-Hot-Plate and Heat Flow Meter Method for Absolute Thermal Conductivity Tests Excluding Thermal Contact Resistance

CONFERENCE PAPER · OCTOBER 2003

---

CITATIONS

3

---

READS

19

## 2 AUTHORS:



[Akhan Tleoubaev](#)

TA Instruments

8 PUBLICATIONS 16 CITATIONS

[SEE PROFILE](#)



[Andrzej Brzezinski](#)

Independent Researcher

5 PUBLICATIONS 20 CITATIONS

[SEE PROFILE](#)

**Cover page**

Title: Combined Guarded-Hot-Plate and Heat Flow Meter Method for Absolute Thermal Conductivity Tests Excluding Thermal Contact Resistance Thermal Conductivity 27/Thermal Expansion 15

Authors: Akhan Tleoubaev  
Andrzej Brzezinski

## ABSTRACT

A Combined Guarded Hot Plate and Heat Flow Meter Method was developed and tested for absolute thermal conductivity tests of moderate thermal conductivity (up to  $\sim 10$  W/mK) materials. A thin flat guarded heater of known area is placed between two flat-parallel samples of the same material and of different thicknesses. The stack is clamped between two isothermal plates each having a heat flow meter. Heat flux across each of the two samples is inversely proportional to its total thermal resistance – sum of sample's thermal resistance (thickness divided by thermal conductivity) and its two surface contact resistances, which are assumed to be equal for the two samples. After reaching thermal equilibrium the measured amount of electric power of the heater's central part, its and plates' temperatures, samples' thicknesses and both heat flow meters' readings are used to calculate the material's absolute thermal conductivity excluding the thermal contact resistance. Measurements without taking into account the thermal contact resistance would cause very large errors (as much as hundreds percent in some cases).

This combination of the two traditional steady-state methods provides significantly increased accuracy of the absolute thermal conductivity measurements of many very important materials such as ceramics, glasses, plastics, rocks, polymers, composites, fireproof materials, etc.

Both theoretical aspects of the combined method and its experimental check using some reference materials (Pyrex, Pyroceram, Vespel<sup>®</sup> 1) are presented.

## INTRODUCTION

The two traditional methods most widely used are, the Guarded Hot Plate (ASTM C177, ISO 8302) for absolute values of thermal conductivity, and the Heat Flow Meter (ASTM C518, ISO 8301) for comparative measurements. The latter one was already modified to exclude thermal contact resistance using Procedure of Two-Thickness and Multi-Thickness calibrations and tests [1] used in LaserComp's FOX50 Heat Flow Meter instrument. Thermal contact resistance (or contact resistivity) may cause huge errors of thermal conductivity measurements if it is not taken into account. For example ¼”-(6.35 mm)-thick Pyroceram sample has thermal resistance  $x/\lambda \approx 0.00635\text{m} / 3.9 \text{ W/mK} \approx 1.6 \cdot 10^{-3} \text{ m}^2\text{K/W}$  whereas the thermal contact resistance  $2R$  of the two surfaces of the samples usually is about  $3\text{-}4 \cdot 10^{-3} \text{ m}^2\text{K/W}$  – two times bigger! Similar procedure using data from two specimen of different thickness to generate two independent equations with two unknowns,  $\lambda$  and  $R$ , was used by B.J.Filla and A.J.Slifka at NIST [2].

Sample's thermal resistance (it would be more consistent to call it as “resistivity” rather than “resistance”) is equal to the sample's thickness  $x$  divided by its thermal conductivity (not conductance)  $\lambda$ .

$$R_{sample} = x/\lambda \quad [\text{m}^2\text{K/W}] \quad (1)$$

Thermal contact resistance depends on the types of adjoining materials, their roughness, and the interface pressure and is equal to temperature difference between the two contacting surfaces  $\delta T$  divided by heat flux  $q$  [ $\text{W/m}^2$ ]:

$$R_{contact} = \delta T/q \quad [\text{m}^2\text{K/W}] \quad (2)$$

The total thermal resistance of the sample placed into the instrument equals to:

$$R_{total} = x/\lambda + 2R_{contact} \quad [\text{m}^2\text{K/W}] \quad (3)$$



Figure 1. FOX50 Heat Flow Meter Instrument, LaserComp, Inc.

All Heat Flow Meter instruments are only able to measure *total* thermal resistance because their Heat Flow Meters' (HFM's) signals  $Q$  ( $\mu\text{V}$ ) are proportional to the heat flux  $q$  across the sample, which is proportional to temperature difference  $\Delta T$  between instrument's plates and inversely proportional to the *total* thermal resistance  $R_{total}$  :

$$q = S Q = \Delta T / R_{total} = \Delta T / (x/\lambda + 2R_{contact}) \quad [\text{W}/\text{m}^2] \quad (4)$$

The physical sense of the calibration factor  $S$  [ $\text{W m}^{-2} \mu\text{V}^{-1}$ ] is a heat flux necessary to create 1 microvolt of electric signal on the heat flow meter (transducer) output.

In practice, value of  $2R_{contact}$  includes of course not just thermal contact resistance but also some additional thermal resistance on the HFMs' thermocouples due to lamination of the transducers and paint (transducers are painted by black paint to make the emissivity of their surfaces as big as possible).

In case of thermal insulation materials (small  $\lambda$ ) the sample's thermal resistance is large and thermal contact resistance can be neglected. But in case of higher conductivity materials ( $\lambda > 0.1 \text{ W}/\text{mK}$ ) the thermal contact resistance becomes significant compared to the sample' thermal resistance and cannot be neglected. Fig.2 shows graphs of the total thermal resistance  $R_{total}$  versus samples' thickness  $x$  of several samples of three well-known materials – Pyrex 7740, DuPont Vespel<sup>®</sup> 1, and Pyroceram 9606 [1] (measured by the LaserComp's FOX50 Heat Flow Meter instrument). Extrapolation of each of the graphs down to zero thickness gives the value of thermal contact resistance of the two surfaces ( $2R_{contact}$ ). Reciprocal of the slope ( $\Delta x/\Delta R_{total}$ ) is equal to the correct thermal conductivity of material:

$$\lambda = (x_2 - x_1) / (x_2/\lambda + 2R_{contact} - x_1/\lambda - 2R_{contact}) \quad [\text{W m}^{-1} \text{K}^{-1}] \quad (5)$$

where  $x_1$  and  $x_2$  are thicknesses of the thin and thick samples.

Mathematically, measurements of the total thermal resistance of two samples of different thickness are necessary to calculate both thermal conductivity and thermal contact resistance [1]. Multi-thickness tests, of course, give better accuracy. Thermal contact resistances are assumed to be the same for all the same material samples. So the samples surface finish should have the same quality.

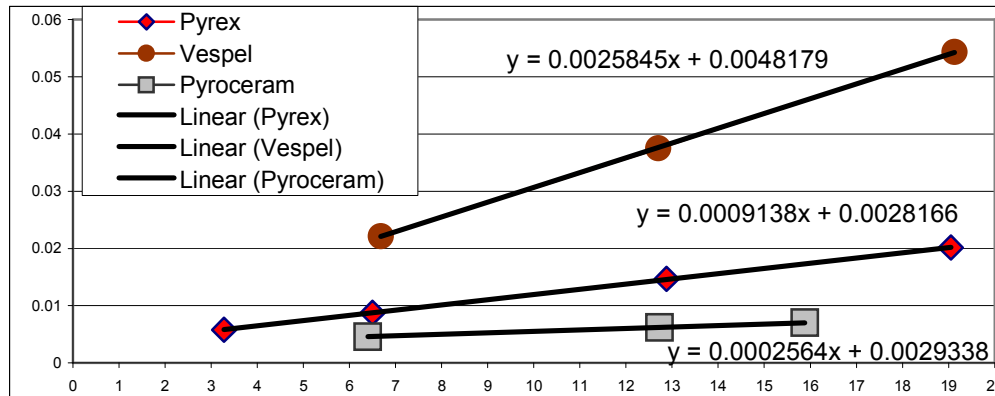

Figure 2. Total thermal resistance in  $\text{m}^2\text{K}/\text{W}$  versus samples' thickness  $x$  in millimeters.

To calibrate the Heat Flow Meter Instruments' transducers (to obtain  $S$ ) a special Two-Thickness Procedure has to be done using two different thickness samples of materials with well-known thermal conductivity like Pyrex 7740 etc. (see [1] or the FOX50 Instrument's Manual). Calibration factors always appear to be almost the same (within few percent) no matter what material - Pyrex, Pyroceram, or Vespel<sup>®</sup> - was used for calibration.

## THE NEW COMBINED METHOD DESCRIPTION

If we combine the two traditional methods used for thermal conductivity tests – the Guarded-Hot-Plate and the Heat Flow Meter methods, it will allow us to obtain accurate absolute values of thermal conductivity excluding thermal contact resistance by testing two samples of different thickness simultaneously (see Fig.3).

A guarded flat heater of known square area placed between two samples of different thickness gives information about *total* heat flux. The two Heat Flow Meters' signals ratio gives information about how the heat flux is *shared* between thin and thick samples. Temperature of the heater is, say 20<sup>0</sup>C higher than the both plates' temperature. Temperatures of the sample's surfaces are not equal to the heater's and plates' temperatures because of the thermal contact resistance. Isothermal upper and lower plates made of red copper, guard heater controlled by the zero Heat Flow Meter (to eliminate any lateral heat flow) and thick surrounding insulation guarantee that we have strictly uniform one-dimensional vertical heat flow within the samples.

To find two unknowns – thermal conductivity  $\lambda$  and thermal contact resistance  $2R$  - we have a system of equations:

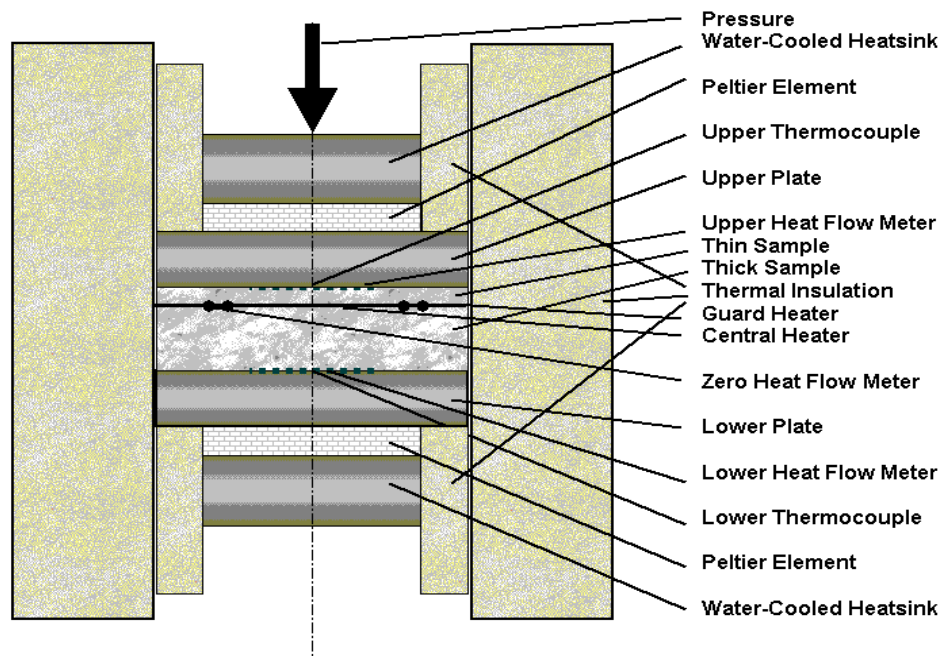

Figure 3. Schematic diagram of the experimental system.

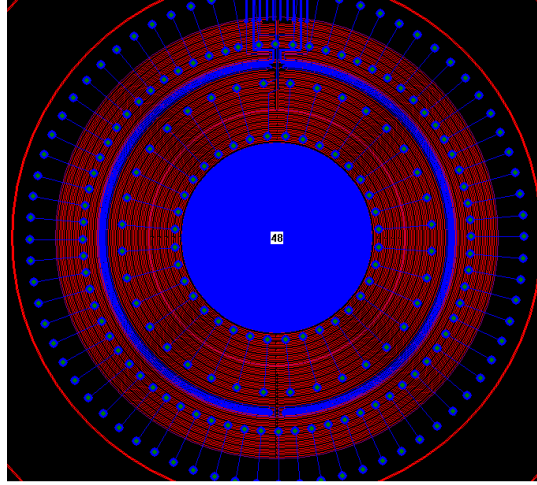

Figure 4. Guarded-Hot-Plate heater design.  
 Central zone diameter is 36.9 mm. Guard zone outer diameter is 63.5 mm (2.5")  
 (outer lateral Heat Flow Meter is not used).

1) Heat flux through the thin sample:

$$q_1 = \Delta T / (x_1 / \lambda + 2R) = S_1 Q_1 \quad (6)$$

2) Heat flux through the thick sample:

$$q_2 = \Delta T / (x_2 / \lambda + 2R) = S_2 Q_2 \quad (7)$$

3) Power of the heater  $W$  (center) divided by it's square area  $A$ :

$$W/A = q_1 + q_2 \quad (8)$$

where  $S_1$ ,  $S_2$ ,  $Q_1$ , and  $Q_2$  are the Heat Flow Meters' calibration factors and signals.

The guarded flat heater must be symmetrical – i.e. the flat heat source must be located in the middle of the heater's body and both sides lamination should have same thermal resistance. This can be checked by flipping the heater up side down during the Heat Flow Meters comparison procedure.

Before the measurements the two Heat Flow Meters must be compared using two same samples (of same material and of same thickness).

$$Q_{1c} S_1 = Q_{2c} S_2 = W/2A \quad [\mu V] \quad (9)$$

There is the same heat flux across the two same samples and the signals  $Q_1$  and  $Q_2$  are inversely proportional to Heat Flow Meters' calibration factors  $S_1$  and  $S_2$  (which are not necessarily the same, and which are not necessary to determine in this case):

$$Q_{1c} \sim 1/S_1 \quad [\mu V] \quad Q_{2c} \sim 1/S_2 \quad [\mu V] \quad (9')$$

The solution of the system of equations (6-8) now can be written in ratios of the Heat Flow Meters' signals with no use of their calibration factors:

$$\lambda = (\Delta x / \Delta T) (W/A) / [(Q_1/Q_2)/(Q_{1c}/Q_{2c}) - (Q_{1c}/Q_{2c})/(Q_1/Q_2)] \quad (10)$$

$$2R = (\Delta T / \Delta x) / (W/A) \cdot [\Delta x + x_2 (Q_{1c}/Q_{2c})/(Q_1/Q_2) - x_1 (Q_1/Q_2)/(Q_{1c}/Q_{2c})] \quad (11)$$

where  $\Delta x = x_2 - x_1$  is the two samples' thickness difference. (The HFM signals comparison ratio  $Q_{1c}/Q_{2c}$  is about 1).

Uncertainty of the thermal conductivity measurements is small due to all the Heat Flow Meters' signals in formula (10) are presented in ratios thus eliminating bias errors, or at least most of them. Uncertainty due to all other measured values is small as well and can be estimated as:

$$\delta\lambda/\lambda \approx [(\delta\Delta x/\Delta x)^2 + (\delta\Delta T/\Delta T)^2 + 2(\delta U/U)^2 + (\delta R_{ref}/R_{ref})^2 + (\delta A/A)^2]^{1/2} \approx \quad (12)$$

$$\approx [(\sim 0.025\text{mm}/\sim 10\text{-}20\text{mm})^2 + (\sim 0.1^\circ/20^\circ)^2 + 2(\sim 0.005\%)^2 + (\sim 0.1\%)^2 + (\sim 0.5\%)^2]^{1/2} \approx \underline{1\%}$$

Of course, real life uncertainty is not so small, because not all of the factors are taken into account, but nevertheless, formula (10) can be considered as most accurate for practical use.

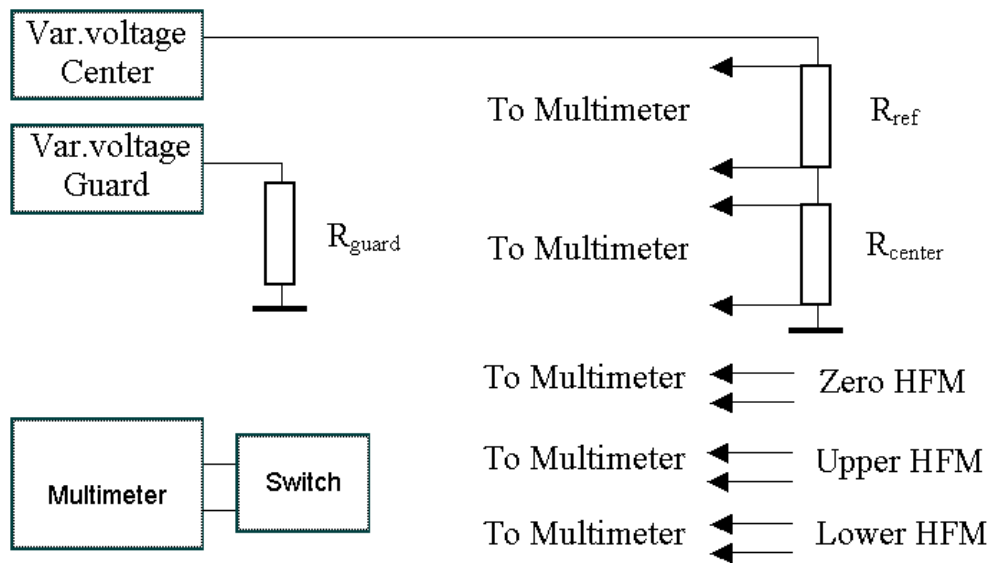

Figure 5. Simplified electronic circuit for the New Combined Method.



## EXPERIMENTAL SYSTEM DESCRIPTION

Simplified electronic circuit of the experimental system is shown on Fig.5. Central heater  $R_{center}$  is connected in series with precise reference resistor  $R_{ref}$  (Vishay VPR221, 20 Ohm, 4 wires contacts, 0.1%) mounted on heatsink to prevent its heating. Hewlett-Packard (now Agilent Technologies) 6½-digit 34401A digital multimeter measures all the DC voltages (including the microvolt range signal from the zero HFM with 0.1 microvolt resolution) with ~0.005% accuracy (for voltages used in calculations). Two sources of variable DC are used to control powers, and consequently, the temperatures of the central and guard heaters. The voltages can be adjusted with high resolution sufficient to reach the heater's set point temperature within ~0.02°C, and to minimize the zero HFM signal (proportional to temperature difference between the central and the guard zones) down to a fraction of microvolt. The plates' (or Heat Flow Meter's) E-type thermocouples are mounted at the very surfaces of the Heat Flow Meters (the red copper plates assemblies are parts of the regular FOX50 Heat Flow Meter instrument).

Temperature  $T$  and power  $W$  of the central heater are calculated using voltage drops on it and on the reference resistor (separate sense wires are used to exclude resistance of connecting wires). Accurate temperature-resistance calibration (at very small voltage to prevent heating) of the central heater at 3 temperatures gives the heater's resistance at 0°C -  $R_0$ , and  $\alpha$  (linear) and  $\beta$  (quadratic) coefficients of the  $R$ - $T$  relation,

$$R(T, ^\circ C) = R_0 (1 + \alpha T + \beta T^2) \quad (13)$$

so the heater's temperature  $T$  (usually it is 20°C higher than the Heat Flow Meters' temperature) can be calculated from its resistance (using reverse formula without subtraction of two close numbers to avoid rounding errors):

$$T(R) = 2(R/R_0 - 1) / \{ \alpha + [\alpha^2 + 4\beta(R/R_0 - 1)]^{1/2} \} \quad (14)$$

After reaching the final thermal equilibrium the accurate values of the thermal conductivity  $\lambda$  and thermal contact resistance  $2R$  are calculated using formulas (10) and (11). Temperature of the test is calculated as mean temperature of the heater (formula (14)) and temperature of the Heat Flow Meters measured by their thermocouples.

## TESTS RESULTS

To verify the new Combined Method and its formulas we tested materials of well-known thermal conductivity – Pyrex 7740, Pyroceram 9606, DuPont Vespel® 1- samples we routinely use to calibrate our FOX50 Heat Flow Meter instruments. Stainless steel 304 also was tested to check how the method works at higher conductivity materials. Several preliminary tests were done at mean room temperature 25°C (15°C plates' temperature, 35°C heater's temperature), and mean 45°C (35°C and 55°C, respectively).

TABLE I. THERMAL CONDUCTIVITY TESTS RESULTS – PYREX 7740

$T_{\text{mean}}$	This work	Powell et.al. [3] (NBS, 1966)	Tye, Salmon [4] (NPL, 26th Conf.)
25 <sup>0</sup> C	1.111 W/mK	1.094 (+1.6%)	1.142 (-2.8%)
45 <sup>0</sup> C	1.146 W/mK	1.123 (+1.3%)	1.171 (-2.1%)

TABLE 2. THERMAL CONDUCTIVITY TESTS RESULTS (W/mK) – PYROCERAM 9606

$T_{\text{mean}}$	This work	Powell et.al. [3] (NBS, 1966)	Salmon et.al. [5] (NPL, 16th European Conf.)
25 <sup>0</sup> C	3.90 W/mK	3.99 (-2.3%)	4.06 (-3.9%)
45 <sup>0</sup> C	3.87 W/mK	3.90 (-0.8%)	3.95 (-2.0%)

TABLE 3. THERMAL CONDUCTIVITY TESTS RESULTS (W/mK) – DUPONT™ VESPEL®

1

$T_{\text{mean}}$	This work	27th Thermal Cond. Conference
25 <sup>0</sup> C	0.373 W/mK	0.377 (-1.1%)

TABLE 4. THERMAL CONDUCTIVITY TESTS RESULTS – STAINLESS STEEL 304

$T_{\text{mean}}$	This work	goodfellow.com	% différence
25 <sup>0</sup> C	18.7 W/mK	16.3 W/mK	+14.7%

An additional check was done by testing Pyrex 7740 at three temperature differences - variable  $\Delta T$  tests:

TABLE 5. VARIABLE  $\Delta T$  TESTS – PYREX 7740 AT 25<sup>0</sup>C MEAN TEMPERATURE

$\Delta T, ^\circ\text{C}$	$\lambda, \text{W/mK}$	% différence
Powell et.al. [3]	1.094	-
20 <sup>0</sup>	1.103	+0.8%
10 <sup>0</sup>	1.087	-0.7%
30 <sup>0</sup>	1.106	+1.1%

These tests of materials of significantly different thermal conductivity combined with the variable  $\Delta T$  tests prove that the new combined method and its formula work correctly, and can be used with confidence for measurements of *absolute* values of thermal conductivity ( $\lambda$  up to  $\sim 10$  W/mK) for various important materials like ceramics, glasses, plastics, rocks, polymers, composites, fireproof materials, etc. Materials with  $\lambda$  up to  $\sim 20$  W/mK also can be tested, but with lower accuracy, because the samples' thermal resistance difference ( $\Delta x/\lambda$ ) becomes much smaller than thermal contact resistance  $2R$ .

## CONCLUSIONS

The new Combined Guarded-Hot-Plate and Heat Flow Meter method was developed for accurate *absolute* thermal conductivity tests excluding thermal contact resistance. Accuracy of the new method is very good because formulas derived for this method are written in ratios of the Heat Flow Meters' signals to eliminate bias errors.

Tests results of materials with well-known thermal conductivity like Pyrex 7740, Pyroceram 9606, and DuPont™ Vespel® 1 proved to be very close to their recommended values (within few percent).

As a prospective, the new Combined Method will be used for a special insert of the LaserComp's FOX50 Heat Flow Meter instrument to obtain absolute thermal conductivity values, and its formulas will be used in LaserComp's "WinTherm50" software.

The new Combined Method utilizing advantages of both of the traditional methods will significantly improve accuracy and reliability of thermal conductivity data.

## REFERENCES

1. Brzezinski, A., and A.Tleoubaev. 2002. "Effects of Interface Resistance on Measurements of Thermal Conductivity of Composites and Polymers," Proceedings of the 30<sup>th</sup> North American Thermal Analysis Society Conference, September 23-25, 2002, Pittsburgh, Pennsylvania, K. J. Kociba, ed., Lubrizoil Corp., pp.512-517.
2. Filla, B.J., and A.J.Slifka. 1997. "Thermal Conductivity Measurements of Pyroceram 9606 Using a High-Temperature Guarded-Hot-Plate" in *Thermal Conductivity 24 & Thermal Expansion 12*, P. S. Gaal and D. E. Apostolescu, eds. October 26-29, 1997, Pittsburgh, PA, Lancaster-Basel: Technomics, pp. 85-96.
3. Powell, R.W., et.al. 1966 *Thermal Conductivity of Selected Materials*, National Standard Reference Data Series – National Bureau of Standards – 8, 25 November 1966.
4. Tye, R.P., and D.R.Salmon. 2001. "Thermal Conductivity Reference Materials: Polymethylmethacrylate and Pyrex 7740," in *26<sup>th</sup> International Thermal Conductivity Conference & 14<sup>th</sup> International Thermal Expansion Conference* 6-8 August 2001, Abstracts & Program, Cambridge, Massachusetts, USA, p.71.
5. Salmon, D.R., R.Brandt and R.P.Tye. 2002. "Pyroceram 9606, a Certified Ceramic Reference Material for High Temperature Thermal Properties Measurements: Part 2 Certification of Measurements" in *The Sixteenth European Conference on Thermophysical Properties - ECTP-2002* Book of Abstracts, 1-4 September 2002, Imperial College, London, UK, pp.269-270.